









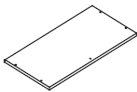
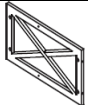
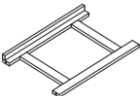

SAVE THESE INSTRUCTIONS

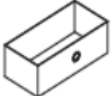
SIMPLE BY DESIGN 2 DRAWER STORAGE UNIT ASSEMBLY INSTRUCTIONS

STYLE #: 73SDRST03

ASSEMBLE ON A FLAT, PROTECTED SURFACE

PHILLIPS HEAD SCREWDRIVER NEEDED FOR ASSEMBLY; NOT INCLUDED

PART LIST	FIGURE	QUANTITY	DESCRIPTION
A		1 PC	TOP PANEL
B		2 PCS	SIDE PANEL
C		1 PC	SHELF
D		1 PC	BOTTOM SHELF
E		2 PCS	DRAWER
F		2 PCS	DRAWER BOTTOM
G		4 PCS + 1 PC	CAM BOLT
H		4 PCS + 1 PC	CAM LOCK
I		8 PCS + 1 PC	BOLT (1/4" x 1 3/4")
J		8 PCS + 1 PC	BARREL NUT
K		8 PCS + 1 PC	LONG SCREW (3/16" x 1/2")
L		2 PCS	BACK WHEEL
M		2 PCS	FRONT LOCKING WHEEL



SAVE THESE INSTRUCTIONS

SIMPLE BY DESIGN 2 DRAWER STORAGE UNIT ASSEMBLY INSTRUCTIONS (CONTINUED)

STYLE #: 73SDRST03

ASSEMBLE ON A FLAT, PROTECTED SURFACE

PHILLIPS HEAD SCREWDRIVER NEEDED FOR ASSEMBLY; NOT INCLUDED

N		2 PCS + 1 PC	SHORT SCREW (1/8" x 1/2")
O		2 PCS	DRAWER STOP
P		4 PCS + 1 PC	CAP

ASSEMBLY INSTRUCTIONS (CONTINUED)

STYLE #: 73SDRST03

STEP 1

A. PLACE TOP PANEL (A) UPSIDE DOWN ON A FLAT, PROTECTED SURFACE.

B. INSERT CAM BOLTS (G) INTO TOP PANEL (A) USING PHILLIPS HEAD SCREWDRIVER, NOT INCLUDED. TIGHTEN COMPLETELY.

C. ATTACH DRAWER STOP (O) TO TOP PANEL (A) WITH SHORT SCREW (N) USING PHILLIPS HEAD SCREWDRIVER, NOT INCLUDED. TIGHTEN COMPLETELY.

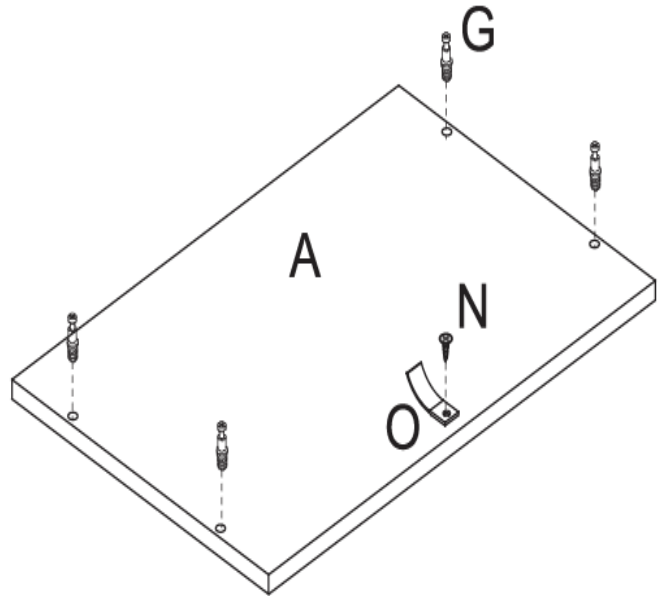

STEP 2

A. PLACE BOTTOM SHELF (D) UPSIDE DOWN ON A FLAT, PROTECTED SURFACE.

B. ATTACH BACK WHEELS (L) AND FRONT LOCKING WHEELS (M) TO BOTTOM SHELF (D) WITH LONG SCREWS (K) USING PHILLIPS HEAD SCREWDRIVER, NOT INCLUDED. TIGHTEN COMPLETELY.

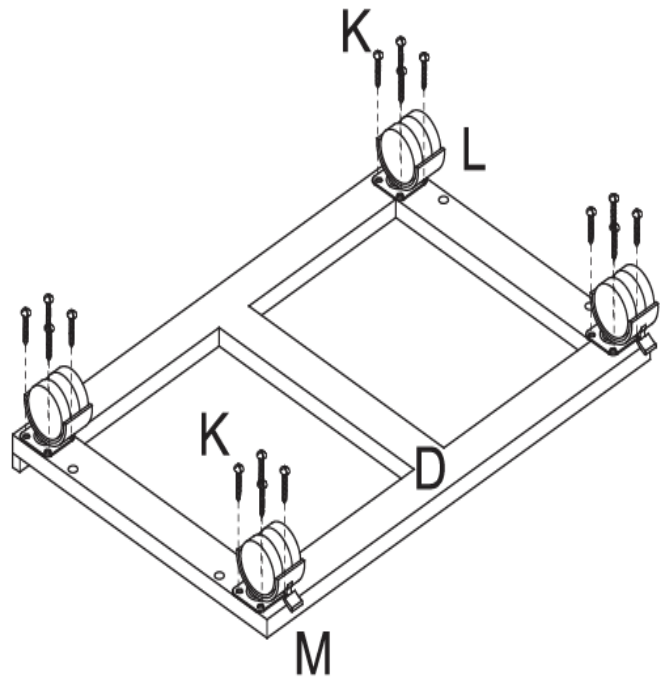

ASSEMBLY INSTRUCTIONS (CONTINUED)

STYLE #: 73SDRST03

STEP 3

A. PLACE SHELVES (C) UPSIDE DOWN ON A FLAT, PROTECTED SURFACE.

B. ATTACH DRAWER STOPS (O) TO SHELVES (C) AT FRONT WITH SHORT SCREWS (N) USING PHILLIPS HEAD SCREWDRIVER, NOT INCLUDED. TIGHTEN COMPLETELY.

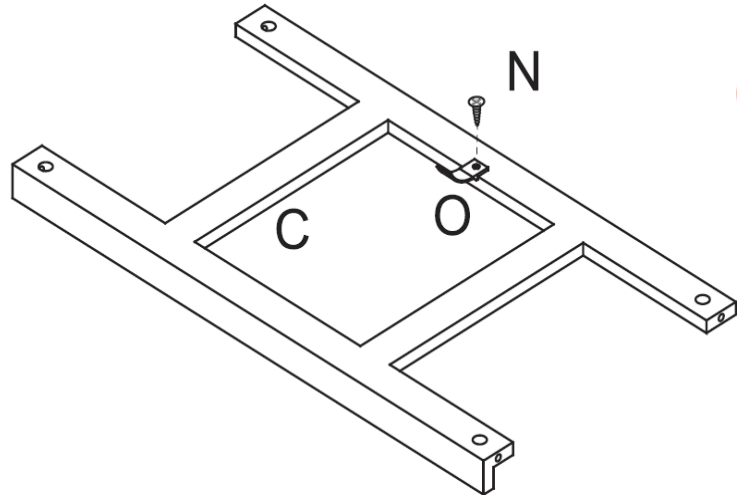

STEP 4

A. SET SIDE PANELS (B) ONTO CAM BOLTS (G) IN TOP PANEL (A).

B. INSERT CAM LOCKS (H) INTO SIDE PANELS (B).

C. TURN CAM LOCKS (H) USING PHILLIPS HEAD SCREWDRIVER, NOT INCLUDED, TO SECURE SIDE PANELS (B) TO TOP PANEL (A).

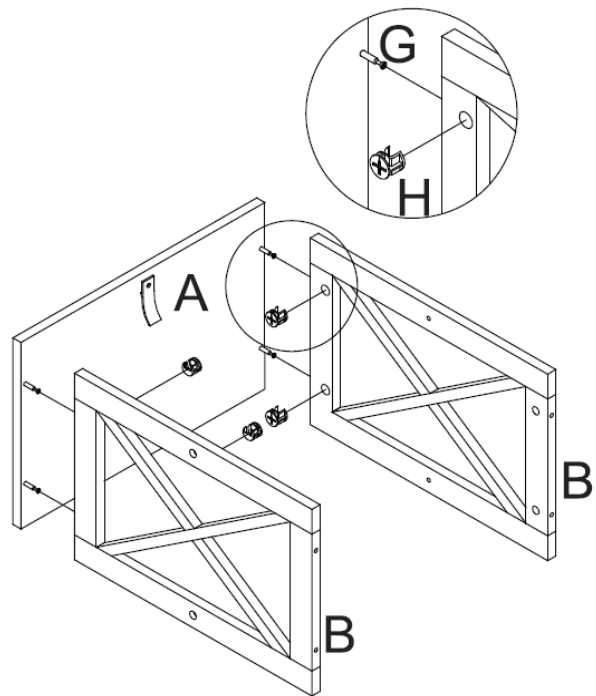

ASSEMBLY INSTRUCTIONS (CONTINUED)

STYLE #: 73SDRST03

STEP 5

A. INSERT BARREL NUTS (J) INTO HOLES ON SHELVES (C) AT BOTTOM.

B. ATTACH SHELVES (C), KEEPING DRAWER STOPS AT FRONT, TO SIDE PANELS (B) WITH BOLTS (I) USING PHILLIPS HEAD SCREWDRIVER, NOT INCLUDED. DO NOT TIGHTEN COMPLETELY.

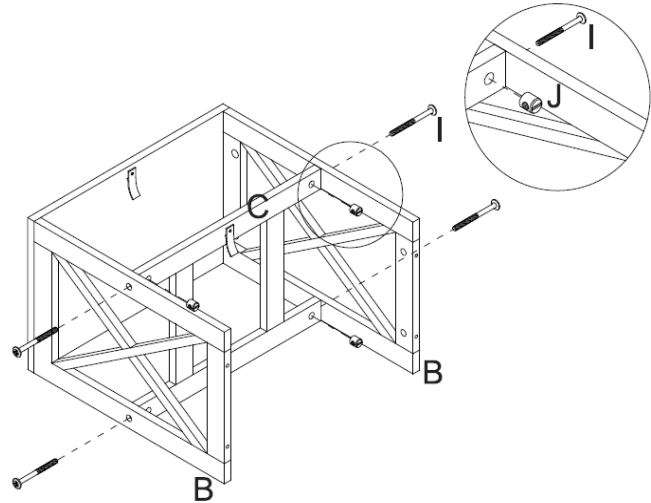

STEP 6

A. INSERT BARREL NUTS (J) INTO HOLES OF SIDE PANELS (B) AT BOTTOM.

B. ATTACH BOTTOM SHELF (D) WITH LOCKING WHEELS (M) AT FRONT TO SIDE PANELS (B) WITH BOLTS (I) USING PHILLIPS HEAD SCREWDRIVER, NOT INCLUDED. TIGHTEN COMPLETELY.

C. TIGHTEN COMPLETELY ALL BOLTS (I) FROM STEP 5.

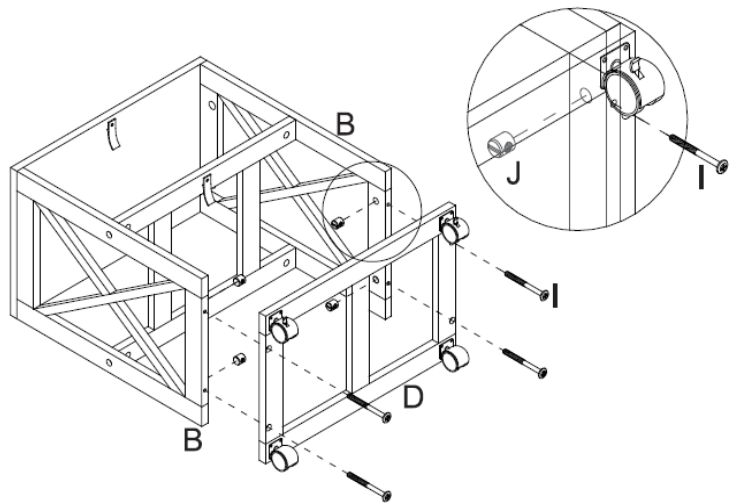

ASSEMBLY INSTRUCTIONS (CONTINUED)

STYLE #: 73SDRST03

STEP 7

A. UNFOLD DRAWERS (E).

B. INSERT DRAWER BOTTOMS (F) INTO DRAWERS (E).

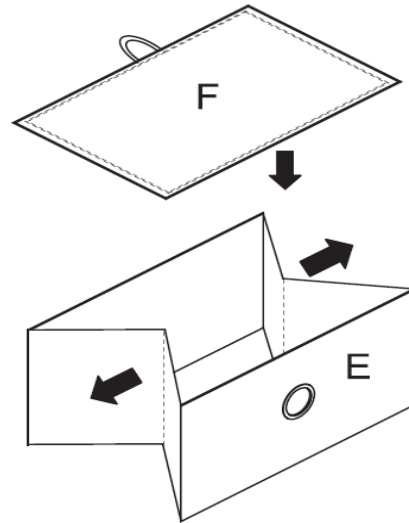

STEP 8

A. ROTATE ASSEMBLED UNIT TO THE UPRIGHT POSITION.

B. PLACE ASSEMBLED DRAWERS (E) INTO THE ASSEMBLED UNIT AS SHOWN.

C. PRESS CAPS (P) INTO BOLT HOLES AT SIDE PANELS (B).

D. ASSEMBLY IS COMPLETE.

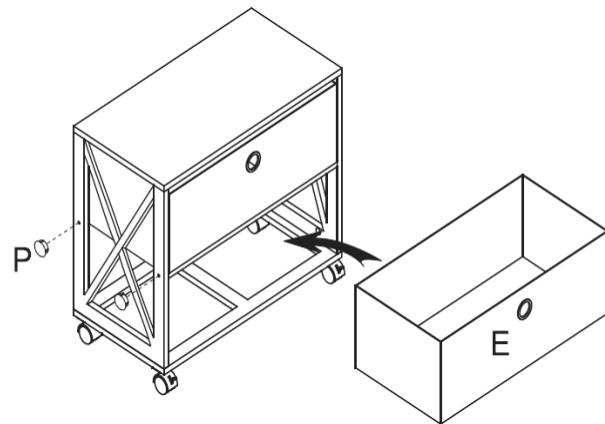

** WE RECOMMEND THAT YOU PERIODICALLY TIGHTEN ALL BOLTS AND SCREWS WITH PHILLIPS HEAD SCREWDRIVER, NOT INCLUDED.

WEIGHT LIMIT

TOP: 40 LBS; DRAWERS: 10 LBS EACH

CARE AND CLEANING

FRAME: WIPE CLEAN WITH A SOFT, DRY CLOTH AS NEEDED.

DRAWERS: SPOT CLEAN WITH A DAMP, CLEAN CLOTH AS NEEDED. DO NOT RUB.

DO NOT SIT, STAND, OR CLIMB ON THE STORAGE UNIT.

WHEN USING STORAGE DRAWERS, DO NOT OVEREXTEND DRAWERS AS WEIGHT COULD CAUSE TIPPING.

INTENDED FOR INDOOR USE ONLY