

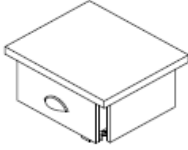





**SAVE THESE INSTRUCTIONS**  
**SONOMA PRESTON END TABLE ASSEMBLY INSTRUCTIONS**  
**STYLE #: 81SNRTB02**  
**ASSEMBLE ON A FLAT, PROTECTED SURFACE.**

PART LIST	FIGURE	QUANTITY	DESCRIPTION
A		1 PC	TOP
B		4 PCS	LEG
C		1 PC	SHELF
D		12 PCS + 1 PC	FLAT WASHER
E		12 PCS + 1 PC	BOLT
F		1 PC	ALLEN WRENCH

**STEP 1**

A. PLACE TOP (A) UPSIDE DOWN ON A FLAT, PROTECTED SURFACE.

B. REMOVE DRAWER FROM TOP (A).

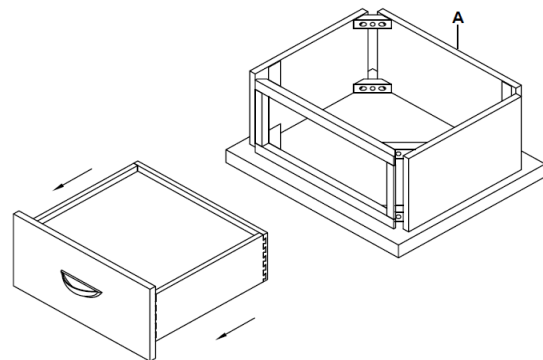

**STEP 2**

A. ATTACH 2 LEGS (B) TO BACK OF TOP (A) WITH BOLTS (E) AND FLAT WASHERS (D) USING ALLEN WRENCH (F). DO NOT TIGHTEN COMPLETELY.

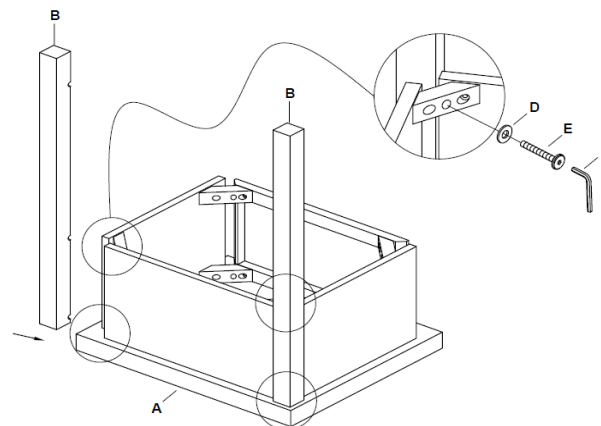

## ASSEMBLY INSTRUCTIONS (CONTINUED)

STYLE #: 81SNRTB02

### STEP 3

A. ATTACH SHELF (C) TO LEGS (B) ON PREASSEMBLED UNIT WITH BOLTS (E) AND FLAT WASHERS (D) USING ALLEN WRENCH (F). DO NOT TIGHTEN COMPLETELY.

B. ATTACH REMAINING 2 LEGS (B) TO TOP (A) AND SHELF (C) WITH BOLTS (E) AND FLAT WASHERS (D) USING ALLEN WRENCH (F).

C. TIGHTEN ALL BOLTS FROM STEPS 1- 3.

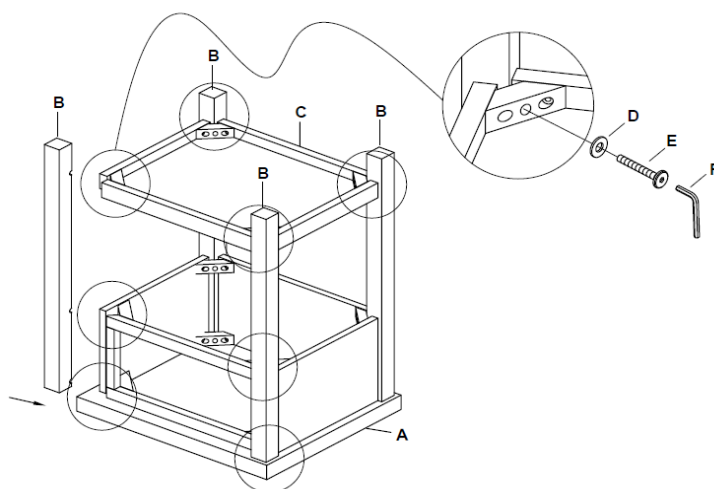

### STEP 4

A. ROTATE ASSEMBLED UNIT UPRIGHT.

B. PLACE THE DRAWER IN TOP (A).

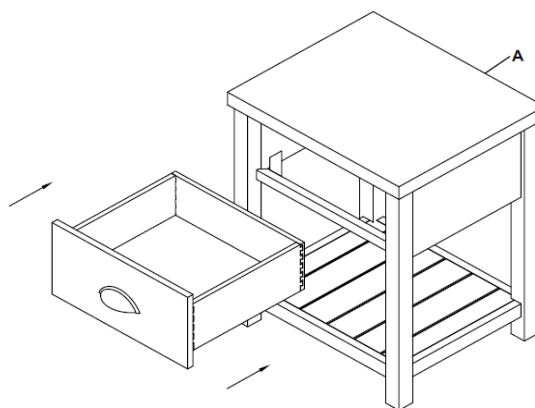

### STEP 5

A. ASSEMBLY IS COMPLETE.

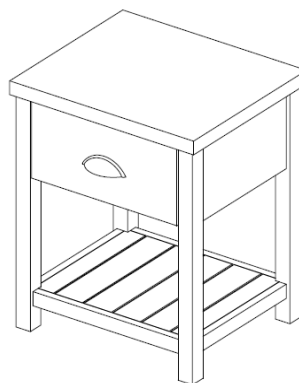

\*\* WE RECOMMEND THAT YOU SAVE THE ALLEN WRENCH (F) AND PERIODICALLY TIGHTEN ALL BOLTS.

#### WEIGHT LIMIT:

TOP: 40 LBS, DRAWER: 10 LBS, SHELF: 20 LBS.

#### CARE AND CLEANING

WIPE CLEAN WITH A SOFT, DRY CLOTH AS NEEDED.

DO NOT SIT, STAND, OR CLIMB ON THE TABLE.

INTENDED FOR INDOOR USE ONLY.