

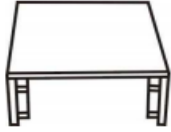





# SAVE THESE INSTRUCTIONS

## SONOMA PRESIDIO OTTOMAN

STYLE #: 61SRR4511

ASSEMBLE ON A FLAT, PROTECTED SURFACE.

PART LIST	FIGURE	QUANTITY	DESCRIPTION
A		1 PC	SEAT
B		2 PC	LEG
C		8 PCS + 1 PC	BOLT (Φ8X20MM)
D		8 PCS + 1 PC	WASHER
E		8 PCS + 1 PC	BOLT CAP
F		1 PC	ALLEN WRENCH
G		1 PC	SEAT CUSHION

## ASSEMBLY INSTRUCTIONS (CONTINUED)

STYLE #: 61SRR4511

### STEP 1

A. PLACE LEG (B) ON A FLAT, PROTECTED SURFACE.

B. ATTACH SEAT (A) TO LEG (B) WITH BOLT (C) WITH WASHER (D) USING ALLEN WRENCH (F). DO NOT TIGHTEN COMPLETELY.

C. REPEAT FOR SECOND LEG (B).

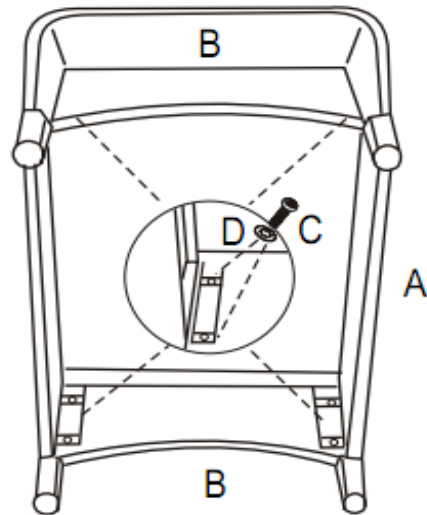

### STEP 2

A. TIGHTEN COMPLETELY ALL BOLTS (C) USING ALLEN WRENCH (F).

B. COVER BOLTS WITH BOLT CAPS (E).

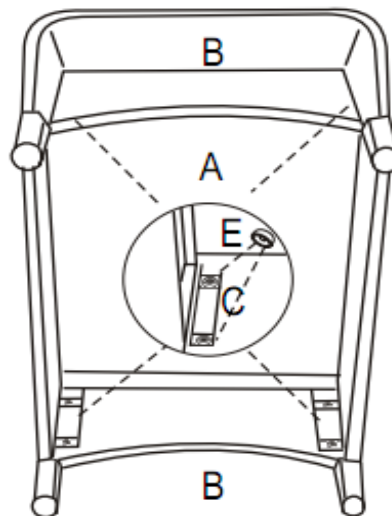

## ASSEMBLY INSTRUCTIONS (CONTINUED)

STYLE #: 61SRR4511

### STEP 3

- A. ROTATE OTTOMAN TO THE UPRIGHT POSITION.
- B. PLACE SEAT CUSHION (G) ON THE OTTOMAN.
- C. ASSEMBLY IS COMPLETE.

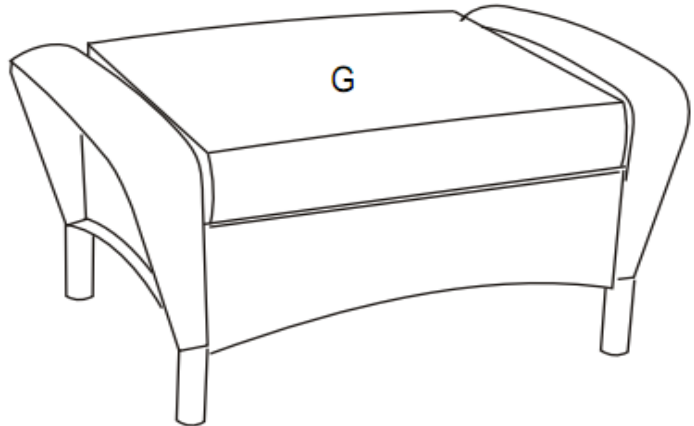

\*\* WE RECOMMEND THAT YOU SAVE THE ALLEN WRENCH (F) AND PERIODICALLY TIGHTEN ALL BOLTS

#### WEIGHT LIMIT

OTTOMAN: 150 LBS

#### CARE AND CLEANING

WASH FRAME WITH MILD SOLUTION OF SOAP AND WATER, RINSE WITH CLEAN WATER AND DRY THOROUGHLY.  
CUSHIONS SHOULD BE SPOT CLEANED WITH A SOFT CLOTH.  
DO NOT STAND OR CLIMB ON THE OTTOMAN.

#### WARRANTY

1 YEAR LIMITED WARRANTY FOR FRAME, WEAVE AND CUSHIONS.

##### WHAT IS COVERED:

WE WARRANT TO THE ORIGINAL PURCHASER FOR ONE YEAR, FROM THE DATE OF PURCHASE, THAT THE FRAME, RESIN WEAVE AND CUSHIONS WILL BE FREE FROM MANUFACTURING DEFECTS. THIS WARRANTY ALSO COVERS PEELING, CRACKING, BLISTERING, DISCOLORATION, OR FADING FOR THIS ONE YEAR PERIOD.

##### WHAT IS NOT COVERED:

IT REMAINS THE CUSTOMER'S RESPONSIBILITY FOR FREIGHT AND PACKAGING CHARGES TO AND FROM OUR SERVICE CENTER. THIS WARRANTY DOES NOT COVER COMMERCIAL USE, ACTS OF NATURE, FIRE, FREEZING, AND ABUSIVE USE. DISCOLORATION OR FADING OF THE FINISH OR FABRICS AS A RESULT OF CHEMICALS OR SPILLS IS NOT COVERED. GLASS TABLETOP BREAKAGE AND CORROSION OR RUSTING OF HARDWARE ARE NOT COVERED. IN ADDITION, PURCHASED PART ARE NOT COVERED UNDER THIS WARRANTY. PROOF OF PURCHASE (DATED REGISTER RECEIPT) IS REQUIRED FOR WARRANTY CLAIMS. WE RESERVE THE RIGHT TO MAKE SUBSTITUTIONS WITH SIMILAR MERCHANDISE, IF THE MODEL IS NO LONGER IN PRODUCTION. WARRANTY IS TO THE ORIGINAL PURCHASER AND IS NOT TRANSFERABLE. AS SOME STATES DO NOT ALLOW EXCLUSIONS OR LIMITATIONS ON AN IMPLIED WARRANTY, THE ABOVE EXCLUSIONS AND LIMITATIONS MAY NOT APPLY. THIS WARRANTY GIVES YOU SPECIFIC RIGHTS, AND YOU MAY ALSO HAVE OTHER RIGHTS, WHICH VARY FROM STATE TO STATE.

#### CUSTOMER SERVICE

FOR REPLACEMENT PARTS OR FOR ADDITIONAL INFORMATION

CALL: 1-800-327-2978 9AM TO 5PM EST, Monday-Friday

EMAIL: [info@grandbasketco.com](mailto:info@grandbasketco.com)