





SAVE THESE INSTRUCTIONS
SONOMA PRESIDIO 45" ROUND DINING TABLE
STYLE #: 61SRR2101
ASSEMBLE ON A FLAT, PROTECTED SURFACE.

PART LIST	FIGURE	QUANTITY	DESCRIPTION
A		1 PC	TABLE TOP
B		4 PCS	LEG
C		8 PCS + 1 PC	BOLT (Φ8X12MM)
D		8 PCS + 1 PC	BOLT CAP
E		1 PC	ALLEN WRENCH

ASSEMBLY INSTRUCTIONS (CONTINUED)

STYLE #: 61SRR2101

STEP 1

A. PLACE TABLE TOP (A) UPSIDE DOWN ON A FLAT, PROTECTED SURFACE.

B. INSERT LEGS (B) INTO THE HOLES OF TABLE TOP (A) SHOWN.

C. ATTACH LEGS (B) TO TABLE TOP (A) USING BOLTS (C). TIGHTEN COMPLETELY USING ALLEN WRENCH (E).

D. COVER ALL BOLTS (C) WITH BOLT CAPS (D).

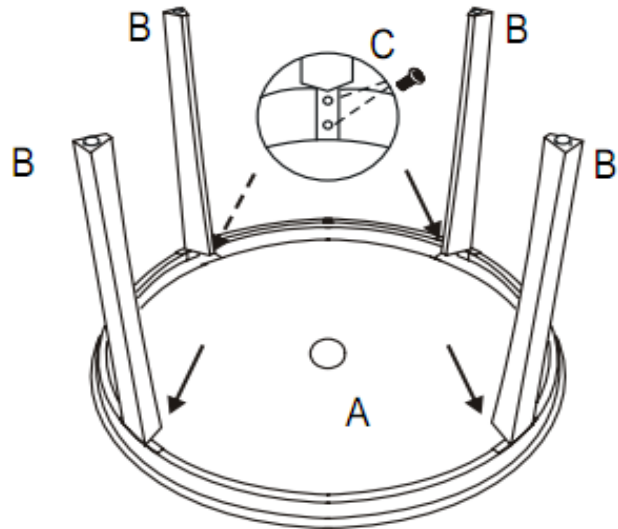

STEP 2

A. ROTATE TABLE TO UPRIGHT POSITION.

B. ADJUST LEG LEVELERS AS NEEDED SO THAT IT SITS STABLE ON THE FLOOR.

C. ASSEMBLY IS COMPLETE.



ASSEMBLY INSTRUCTIONS (CONTINUED)

STYLE #: 61SRR2101

** WE RECOMMEND THAT YOU SAVE THE ALLEN WRENCH (E) AND PERIODICALLY TIGHTEN ALL BOLTS.

WEIGHT LIMIT

200 lbs

CARE AND CLEANING

WASH FRAME WITH MILD SOLUTION OF SOAP AND WATER, RINSE WITH CLEAN WATER AND DRY THOROUGHLY.
CUSHIONS SHOULD BE SPOT CLEANED WITH A SOFT CLOTH.
DO NOT SIT, STAND, OR CLIMB ON THE TABLE.

WARRANTY

1 YEAR LIMITED WARRANTY FOR FRAME, WEAVE AND CUSHIONS.

WHAT IS COVERED:

WE WARRANT TO THE ORIGINAL PURCHASER FOR ONE YEAR, FROM THE DATE OF PURCHASE, THAT THE FRAME, RESIN WEAVE AND CUSHIONS WILL BE FREE FROM MANUFACTURING DEFECTS. THIS WARRANTY ALSO COVERS PEELING, CRACKING, BLISTERING, DISCOLORATION, OR FADING FOR THIS ONE YEAR PERIOD.

WHAT IS NOT COVERED:

IT REMAINS THE CUSTOMER'S RESPONSIBILITY FOR FREIGHT AND PACKAGING CHARGES TO AND FROM OUR SERVICE CENTER. THIS WARRANTY DOES NOT COVER COMMERCIAL USE, ACTS OF NATURE, FIRE, FREEZING, AND ABUSIVE USE. DISCOLORATION OR FADING OF THE FINISH OR FABRICS AS A RESULT OF CHEMICALS OR SPILLS IS NOT COVERED. GLASS TABLETOP BREAKAGE AND CORROSION OR RUSTING OF HARDWARE ARE NOT COVERED. IN ADDITION, PURCHASED PARTS ARE NOT COVERED UNDER THIS WARRANTY. PROOF OF PURCHASE (DATED REGISTER RECEIPT) IS REQUIRED FOR WARRANTY CLAIMS. WE RESERVE THE RIGHT TO MAKE SUBSTITUTIONS WITH SIMILAR MERCHANDISE, IF THE MODEL IS NO LONGER IN PRODUCTION. WARRANTY IS TO THE ORIGINAL PURCHASER AND IS NOT TRANSFERABLE. AS SOME STATES DO NOT ALLOW EXCLUSIONS OR LIMITATIONS ON AN IMPLIED WARRANTY, THE ABOVE EXCLUSIONS AND LIMITATIONS MAY NOT APPLY. THIS WARRANTY GIVES YOU SPECIFIC RIGHTS, AND YOU MAY ALSO HAVE OTHER RIGHTS, WHICH VARY FROM STATE TO STATE.

CUSTOMER SERVICE

FOR REPLACEMENT PARTS OR FOR ADDITIONAL INFORMATION

CALL: 1-800-327-2978 9AM TO 5PM EST, Monday-Friday

EMAIL: info@grandbasketco.com