















SAVE THESE INSTRUCTIONS
SONOMA PRESIDIO CHAISE ASSEMBLY INSTRUCTIONS
STYLE #: 61SRR4401
ASSEMBLE ON A FLAT, PROTECTED SURFACE.

PART LIST	FIGURE	QUANTITY	DESCRIPTION
A		1 PC	SEAT
B		1 PC	BACK
C		1 PC	RIGHT ARM
D		1 PC	LEFT ARM
E		2 PCS	LEG
F		6 PCS + 1 PC	MEDIUM BOLT (Φ8X16MM)
G		10 PCS + 1 PC	WASHER
H		12 PCS + 1 PC	BOLT CAP
I		2 PCS + 1 PC	LONG BOLT (Φ8X60MM)
J		2 PCS + 1 PC	LOCK NUT
K		2 PCS + 1 PC	NUT CAP
L		4 PCS + 1 PC	SHORT BOLT (Φ8X12MM)
M		1 PC	ALLEN WRENCH
N		1 PC	WRENCH
O		1 PC	CUSHION

ASSEMBLY INSTRUCTIONS (CONTINUED)

STYLE #: 61SRR4401

STEP 1

A. PLACE LEFT ARM (C) ON A FLAT, PROTECTED SURFACE.

B. ATTACH SEAT (A) TO LEFT ARM (C) WITH BOLTS (F) AND WASHERS (G) USING ALLEN WRENCH (M). TIGHTEN COMPLETELY.

C. REPEAT FOR RIGHT ARM (D).

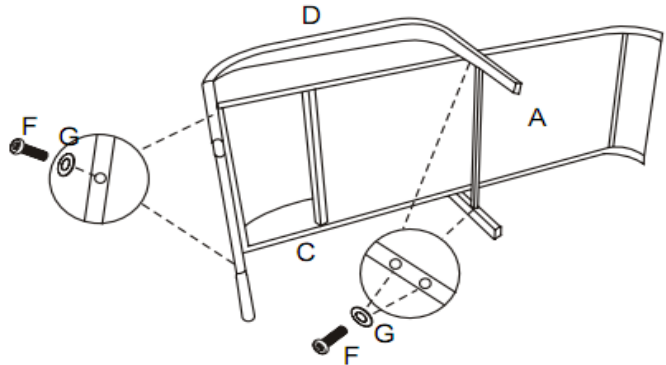

STEP 2

A. ATTACH BACK (B) TO SEAT (A) INSERTING LONG BOLTS (I) THROUGH THE TWO HOLES WITH TWO WASHERS (G) AS SHOWN.

B. SECURE LONG BOLTS (I) WITH LOCK NUTS (J) USING ALLEN WRENCH (M) AND WRENCH (N). TIGHTEN COMPLETELY.

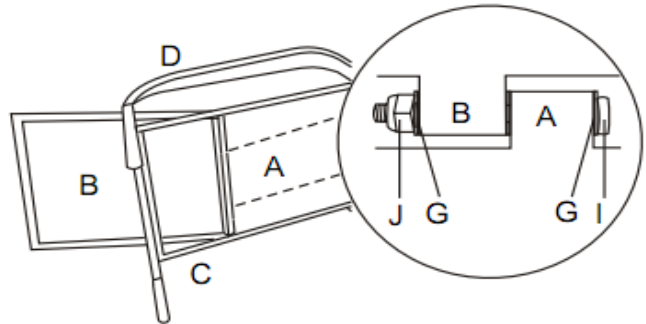

STEP 3

A. ATTACH LEGS (D) TO SEAT (A) WITH SHORT BOLTS (L) USING ALLEN WRENCH (M). TIGHTEN COMPLETELY.

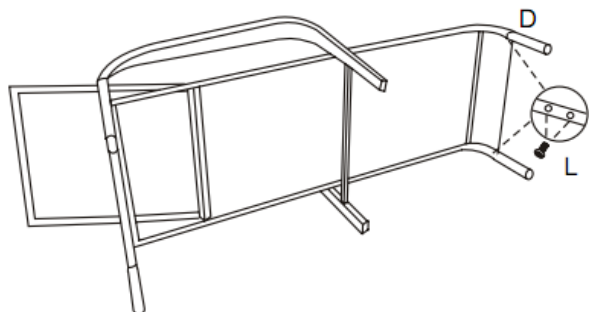

ASSEMBLY INSTRUCTIONS (CONTINUED)

STYLE #: 61SRR4401

STEP 4

A. COVER MEDIUM BOLTS (F), LONG BOLTS (I) AND SHORT BOLTS (L) WITH BOLT CAPS (H).

B. COVER ALL NUTS (J) WITH NUT CAPS (K).

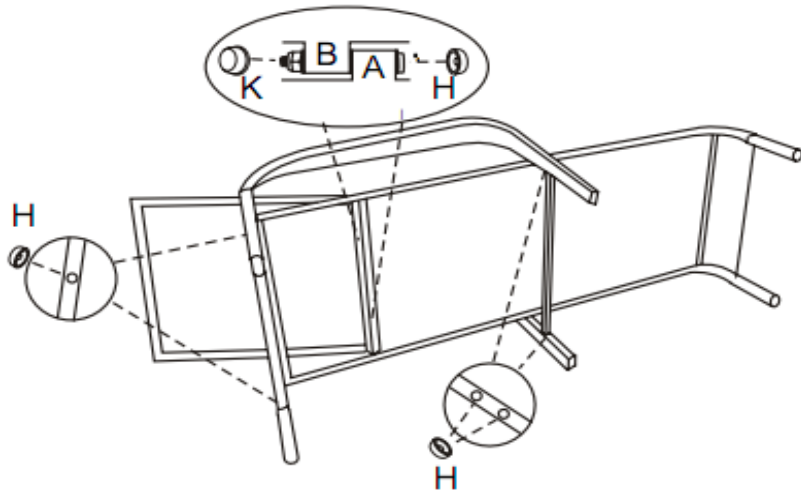

STEP 5

A. ROTATE ASSEMBLED UNIT TO UPRIGHT POSITION.

B. PLACE TOP POCKET OF CUSHION (O) OVER BACK (B).

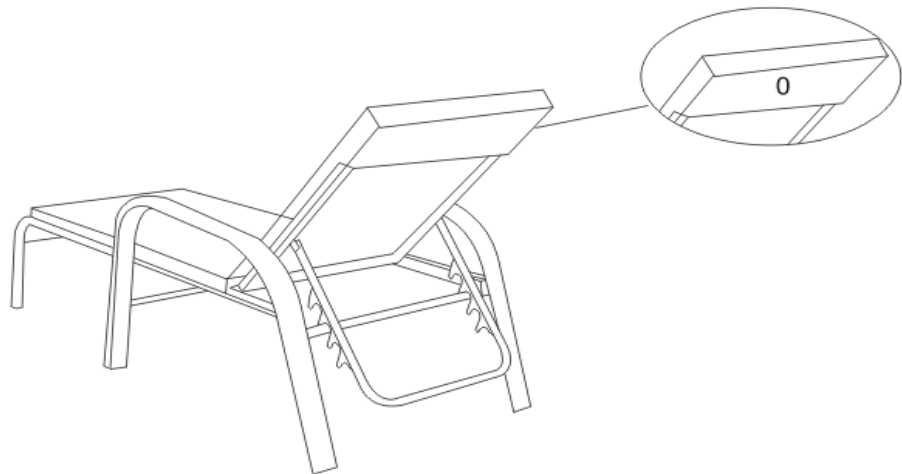

STEP 6

B. CONNECT CUSHION (O) BY THREADING THE CUSHION STRAPS THROUGH SEAT (A) AND BACK (B) CONNECTION AND THROUGH THE RINGS.

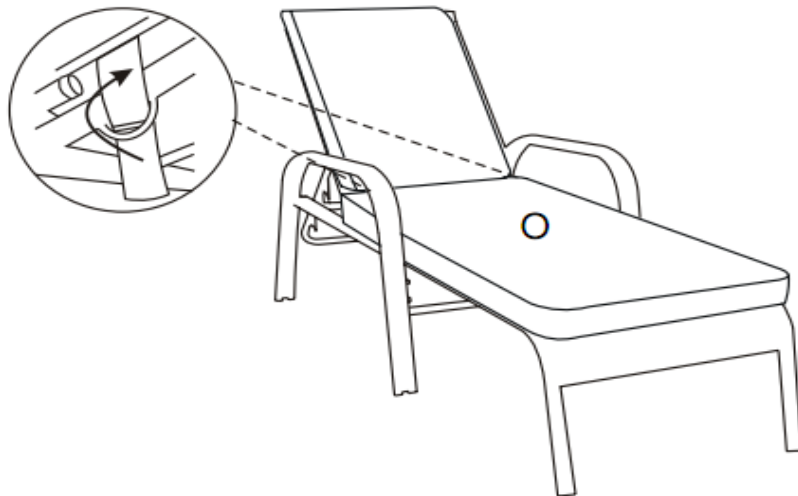

ASSEMBLY INSTRUCTIONS (CONTINUED)

STYLE #: 61SRR4401

**** WE RECOMMEND THAT YOU SAVE THE ALLEN WRENCH AND WRENCH AND PERIODICALLY TIGHTEN ALL BOLTS**

WEIGHT LIMIT

250 LBS

CARE AND CLEANING

WASH FRAME WITH MILD SOLUTION OF SOAP AND WATER, RINSE WITH CLEAN WATER AND DRY CUSHIONS SHOULD BE SPOT CLEANED WITH A SOFT CLOTH.

DO NOT STAND OR CLIMB ON THE CHAISE.

WARRANTY

1 YEAR LIMITED WARRANTY FOR FRAME, WEAVE AND CUSHIONS.

WHAT IS COVERED:

WE WARRANT TO THE ORIGINAL PURCHASER FOR ONE YEAR, FROM THE DATE OF PURCHASE, THAT THE FRAME, RESIN WEAVE AND CUSHIONS WILL BE FREE FROM MANUFACTURING DEFECTS. THIS WARRANTY ALSO COVERS PEELING, CRACKING, BLISTERING, DISCOLORATION, OR FADING FOR THIS ONE YEAR PERIOD.

WHAT IS NOT COVERED:

IT REMAINS THE CUSTOMER'S RESPONSIBILITY FOR FREIGHT AND PACKAGING CHARGES TO AND FROM OUR SERVICE CENTER. THIS WARRANTY DOES NOT COVER COMMERCIAL USE, ACTS OF NATURE, FIRE, FREEZING, AND ABUSIVE USE. DISCOLORATION OR FADING OF THE FINISH OR FABRICS AS A RESULT OF CHEMICALS OR SPILLS IS NOT COVERED. GLASS TABLETOP BREAKAGE AND CORROSION OR RUSTING OF HARDWARE ARE NOT COVERED. IN ADDITION, PURCHASED PART ARE NOT COVERED UNDER THIS WARRANTY. PROOF OF PURCHASE (DATED REGISTER RECEIPT) IS REQUIRED FOR WARRANTY CLAIMS. WE RESERVE THE RIGHT TO MAKE SUBSTITUTIONS WITH SIMILAR MERCHANDISE, IF THE MODEL IS NO LONGER IN PRODUCTION.

WARRANTY IS TO THE ORIGINAL PURCHASER AND IS NOT TRANSFERABLE. AS SOME STATES DO NOT ALLOW EXCLUSIONS OR LIMITATIONS ON AN IMPLIED WARRANTY, THE ABOVE EXCLUSIONS AND LIMITATIONS MAY NOT APPLY. THIS WARRANTY GIVES YOU SPECIFIC RIGHTS, AND YOU MAY ALSO HAVE OTHER RIGHTS, WHICH VARY FROM STATE TO STATE.

CUSTOMER SERVICE

FOR REPLACEMENT PARTS OR FOR ADDITIONAL INFORMATION

CALL: 1-800-327-2978 9AM TO 5PM EST, Monday-Friday

EMAIL: info@grandbasketco.com