







# SAVE THESE INSTRUCTIONS

## CLAREMONT RECTANGULAR DINING TABLE

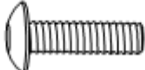
STYLE #: 61SRR2104CLR

ASSEMBLE ON A FLAT, PROTECTED SURFACE.

PART LIST	FIGURE	QUANTITY	DESCRIPTION
A		1 PC	TABLE TOP
B		4 PCS	LEG
C		1 PC	LEG CONNECTOR
D		8 PCS + 1 PC	LONG BOLT (M6*30)
E		8 PCS + 1 PC	SHORT BOLT (M6*25)
F		16 PCS + 1 PC	FLAT WASHER
G		1 PC	ALLEN WRENCH
H		1 PC	UMBRELLA HOLE CAP

\*\*\*If missing or incorrect parts, please call Yotrio directly at 1-866-905-4107

**STYLE #: 61SRR2104CLR**  
**ASSEMBLY INSTRUCTIONS (CONTINUED)**

**STEP 1**

A. PLACE TABLE TOP (A) UPSIDE DOWN ON A FLAT, PROTECTED SURFACE.

B. ATTACH LEGS (B) TO TABLE TOP (A) WITH FLAT WASHERS (F) AND LONG BOLTS (D) USING ALLEN WRENCH (G). DO NOT TIGHTEN COMPLETELY.

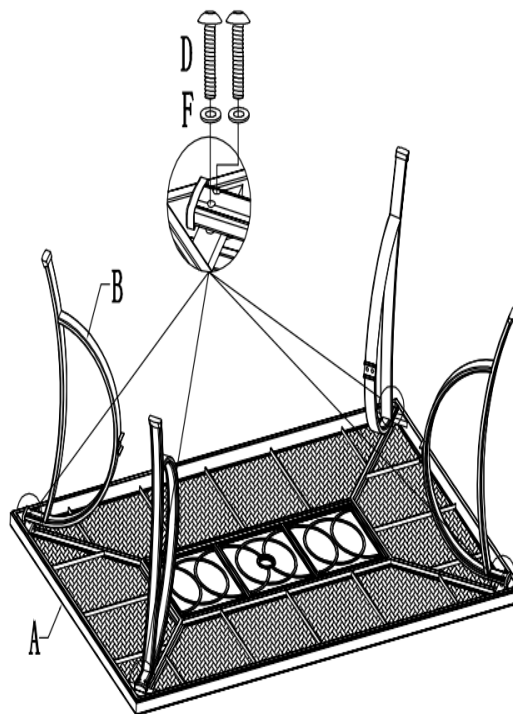

**STEP 2**

A. ATTACH LEG CONNECTOR (C) TO LEGS (B) WITH FLAT WASHERS (F) AND SHORT BOLTS (E) USING ALLEN WRENCH (G). DO NOT TIGHTEN COMPLETELY.

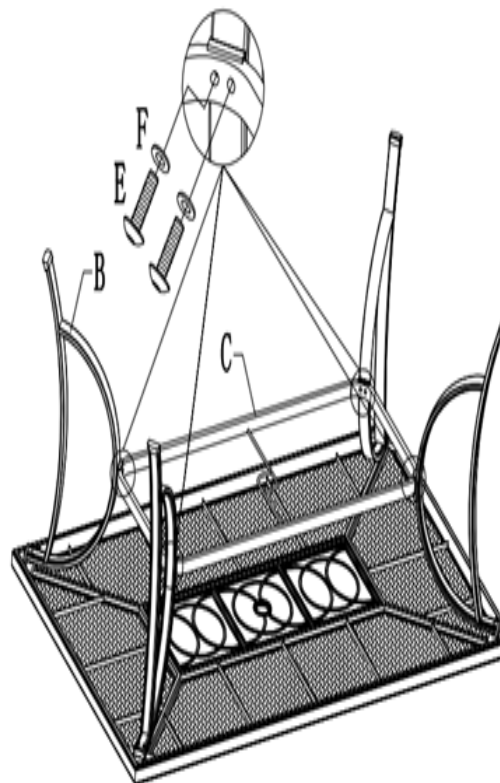

**STYLE #: 61SRR2104CLR**  
**ASSEMBLY INSTRUCTIONS (CONTINUED)**

**STEP 3**

A. CAREFULLY ROTATE TABLE TO THE UPRIGHT POSITION SO THAT IT STANDS STABLE ON THE FLOOR.

B. COMPLETELY TIGHTEN ALL BOLTS (D & E) USING ALLEN WRENCH (G)

C. PLACE UMBRELLA HOLE CAP (H) INTO POSITION ON TABLE TOP (A).

D. ASSEMBLY IS COMPLETE.

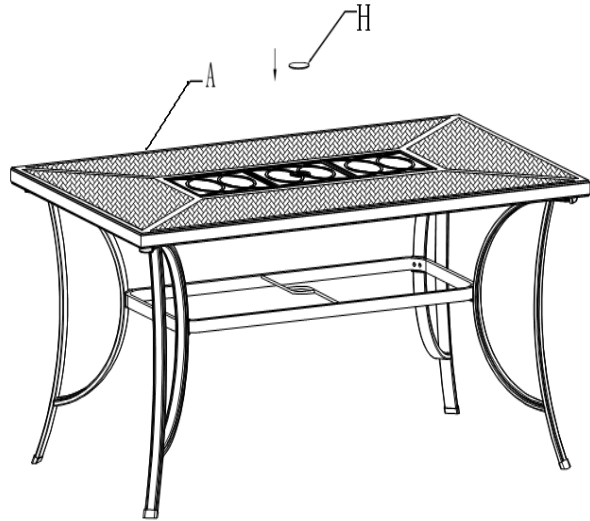

**\*\* WE RECOMMEND THAT YOU SAVE THE ALLEN WRENCH AND PERIODICALLY TIGHTEN ALL BOLTS.**

**WEIGHT LIMIT**

200 LBS

**CARE AND CLEANING**

WIPE CLEAN WITH A MILD SOAP AND WATER SOLUTION, RINSE WITH CLEAN WATER, AND DRY THOROUGHLY.

DO NOT SIT, STAND, OR CLIMB ON THE TABLE.

IN ORDER TO PROLONG THE LIFE OF YOUR TABLE, PLEASE COVER WHEN NOT IN USE OR DURING INCLEMENT WEATHER. DURING THE WINTER SEASON, STORE IN A DRY, SHELTERED PLACE.

**WARRANTY**

1 YEAR LIMITED WARRANTY FOR FRAME.

CUSTOMER SERVICE: PLEASE NOTE - DO NOT RETURN THIS ITEM TO THE RETAILER.

CUSTOMER SERVICE HOT LINE: 1-866-905-4107

SERVICE HOURS: 11:30 A. M. to 8:00 P. M. EASTERN STANDARD TIME /8:30 A. M. to 5:00 P. M. PACIFIC STANDARD TIME

WEBSITE: WWW.YOTRIOINT.COM

TO ASSIST YOU BETTER, PLEASE GATHER THE FOLLOWING INFORMATION BEFORE CALLING CUSTOMER SERVICE: PRODUCT NAME AND STYLE NUMBER, DESCRIPTION AND OR IMAGES OF THE ISSUE, ORIGINAL STORE PURCHASE RECEIPT.