

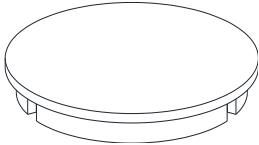

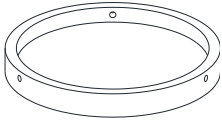
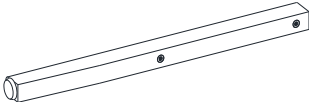
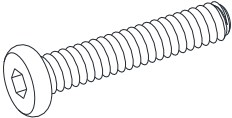
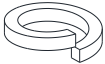

SAVE THESE INSTRUCTIONS
SONOMA CANTON ROUND TABLE ASSEMBLY INSTRUCTIONS
STYLE #: 71SNRTB03
ASSEMBLE ON A FLAT, PROTECTED SURFACE.

| PART LIST | FIGURE | QUANTITY | DESCRIPTION |
|-----------|---|--------------|-------------------------------|
| A |  | 1 PC | TOP |
| B |  | 1 PC | SHELF |
| C |  | 3 PCS | LEG |
| D |  | 6 PCS + 1 PC | BOLT (Dia.5/16" x 40 mm L) |
| E |  | 6 PCS + 1 PC | LOCK WASHER |
| F |  | 6 PCS + 1 PC | FLAT WASHER |
| G |  | 1 PC | ALLEN WRENCH |
| H |  | 1 PC | TOUCH-UP PEN |

ASSEMBLY INSTRUCTIONS (CONTINUED)

STYLE #: 71SNRTB03

STEP 1

A. PLACE TOP (A) UPSIDE DOWN ON A FLAT, PROTECTED SURFACE.

B. ATTACH 2 LEGS (C) TO TOP (A) WITH BOLTS (D), LOCK WASHERS (E), AND FLAT WASHERS (F) USING ALLEN WRENCH (G). DO NOT TIGHTEN COMPLETELY.

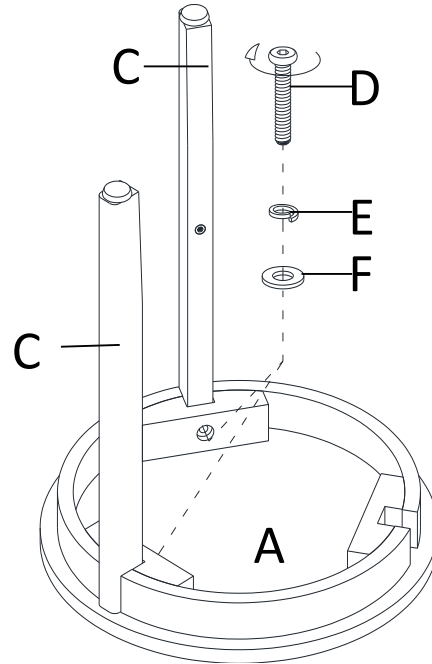

STEP 2

A. ATTACH SHELF (B) UPSIDE DOWN TO LEGS (C) OF PREASSEMBLED UNIT WITH BOLTS (D), LOCK WASHERS (E,) AND FLAT WASHERS (F) USING ALLEN WRENCH (G). DO NOT TIGHTEN COMPLETELY.

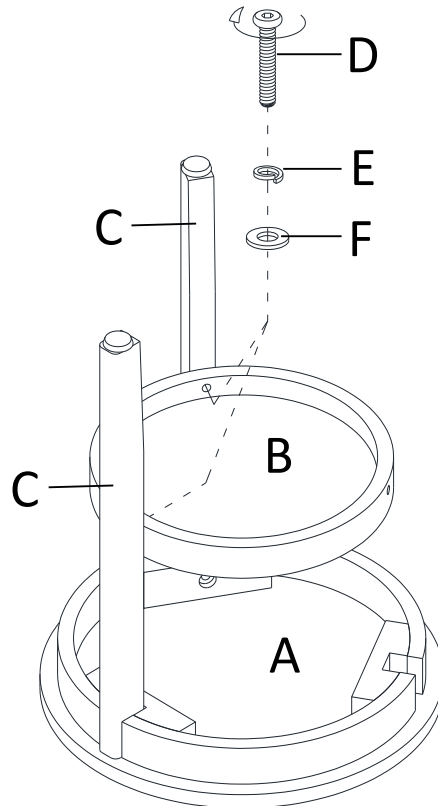

ASSEMBLY INSTRUCTIONS (CONTINUED)

STYLE #: 71SNRTB03

STEP 3

A. ATTACH REMAINDER LEG (C) TO TOP (A) AND SHELF (B) WITH BOLTS (D), LOCK WASHERS (E), AND FLAT WASHERS (F) USING ALLEN WRENCH (G). TIGHTEN BOLTS.

B. TIGHTEN ALL BOLTS FROM PREVIOUS STEPS.

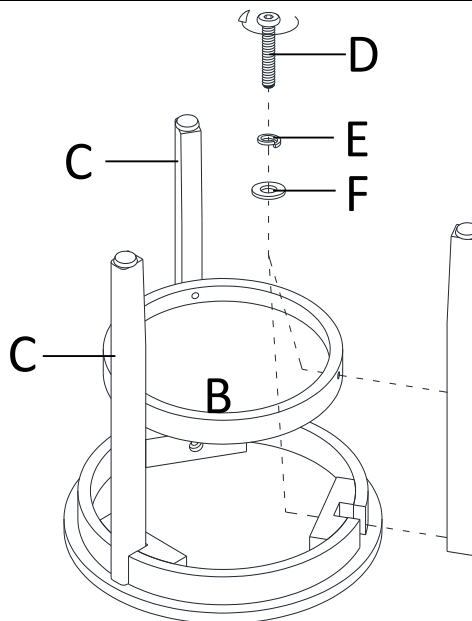

STEP 4

A. ROTATE ASSEMBLED UNIT TO THE UPRIGHT POSITION.

B. ASSEMBLY IS COMPLETE.

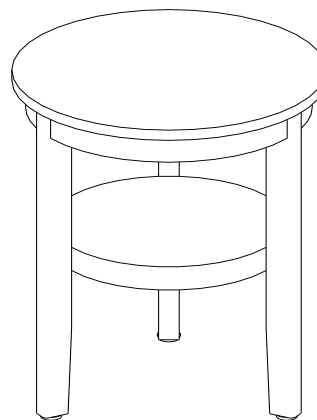

** WE RECOMMEND THAT YOU SAVE THE ALLEN WRENCH (G) AND PERIODICALLY TIGHTEN ALL BOLTS.

WEIGHT LIMIT

TOP: 50 LBS; SHELVES: 50 LBS

CARE AND CLEANING

WIPE CLEAN WITH A SOFT, DRY CLOTH AS NEEDED.

DO NOT SIT, STAND, OR CLIMB ON THE TABLE

INTENDED FOR INDOOR USE ONLY.

USE TOUCH-UP PEN (H) FOR SCRATCHES. STROKE IN DIRECTION OF GRAIN. RUB EXCESS COLOR PROMPTLY WITH A SOFT, DRY CLOTH.

WARRANTY

FOR REPLACEMENT PARTS OR FOR ADDITIONAL INFORMATION,

CALL: 1-866-942-5362 BETWEEN 8:30 A.M. AND 4:30 P.M., PST, MONDAY - FRIDAY.

EMAIL: parts@whalenfurniture.com