

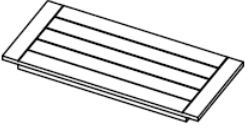





**SAVE THESE INSTRUCTIONS**  
**SONOMA CAMERON 4 TIER BOOKCASE ASSEMBLY INSTRUCTIONS**  
**ASSEMBLE ON A FLAT, PROTECTED SURFACE**

PART LIST	FIGURE	QUANTITY	DESCRIPTION
A		1 PC	TOP
B		4 PCS	SHELF
C		1 PC	RIGHT SIDE FRAME
D		1 PC	LEFT SIDE FRAME
E		20 PCS + 1 PC	BOLT
F		20 PCS + 1 PC	FLAT WASHER
G		10 PCS + 1 PC	WOOD DOWEL
H		1 PC	ALLEN WRENCH

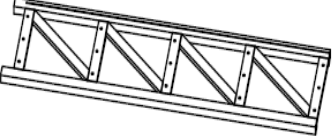
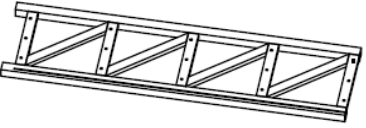
FOR MISSING OR INCORRECT PARTS/HARDWARE, CONTACT THE MANUFACTURER'S CUSTOMER SERVICE DIRECTLY AT  
1-847-608-5202 OR CUSTOMERSERVICE@HOMECIAO.COM

## ASSEMBLY INSTRUCTIONS (CONTINUED)

### STEP 1

A. PLACE TOP (A) UPSIDE DOWN ON A FLAT, PROTECTED SURFACE.

B. INSERT WOOD DOWELS (G) INTO THE DOWEL HOLES ON TOP FRAME (A) AS SHOWN.

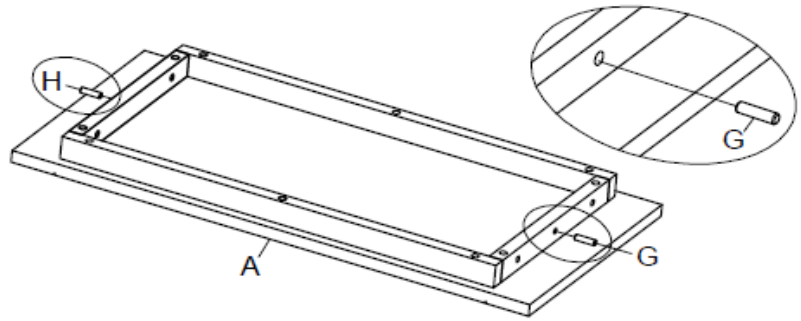

### STEP 2

A. INSERT WOOD DOWEL (G) INTO THE DOWEL HOLES ON SHELVES (B) AS SHOWN.

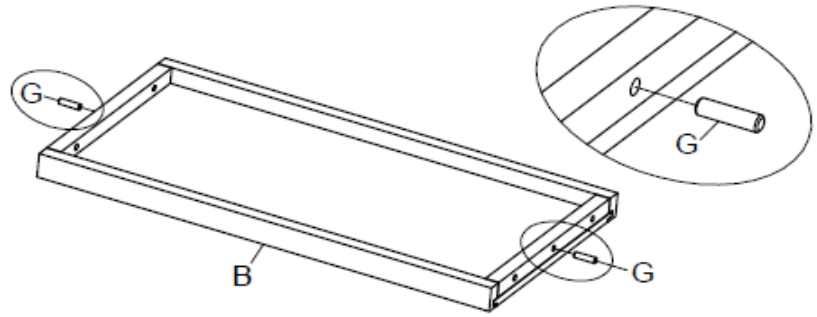

### STEP 3

A. PLACE RIGHT SIDE FRAME (C) ON A FLAT, PROTECTED SURFACE.

B. ATTACH TOP (A) AND SHELVES (B) TO THE RIGHT SIDE FRAME (C) WITH BOLTS (E), FLAT WASHERS (F) AND LOOSELY TIGHTEN USING ALLEN WRENCH (H).

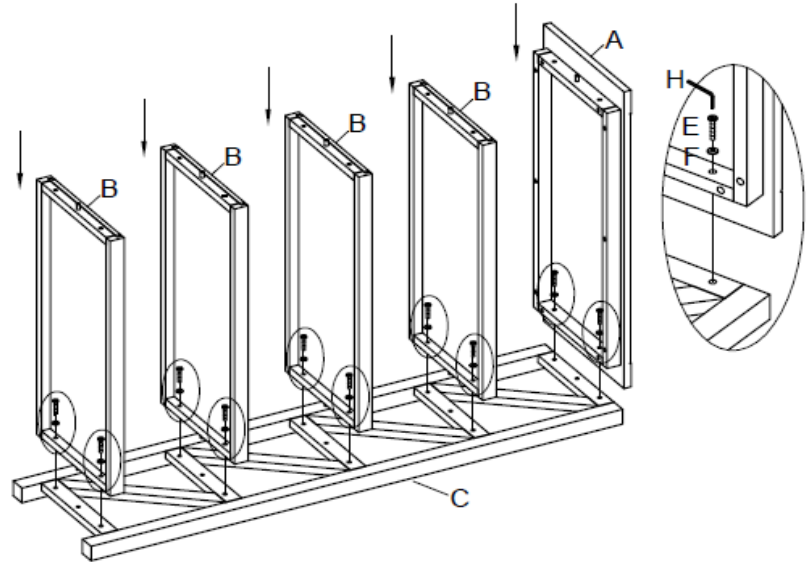

## ASSEMBLY INSTRUCTIONS (CONTINUED)

### STEP 4

A. ATTACH LEFT SIDE FRAME (D) TO ASSEMBLED UNIT FROM STEP 3 WITH BOLTS (E), FLAT WASHERS (F) AND LOOSELY TIGHTEN USING ALLEN WRENCH (H).

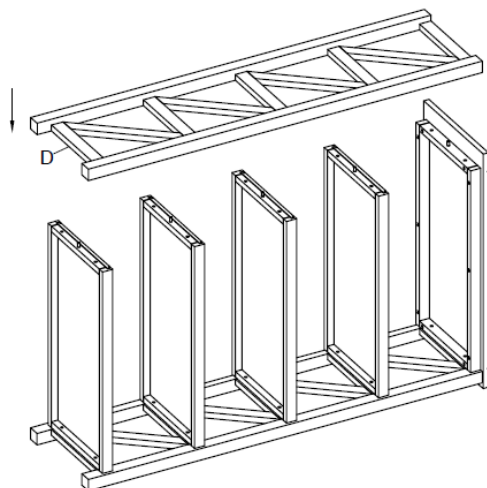

### STEP 5

A. ROTATE THE BOOKCASE UPSIDE DOWN ON A FLAT, PROTECTED SURFACE.

B. FULLY TIGHTEN ALL BOLTS (E) AND FLAT WASHERS (F) WITH ALLEN WRENCH (H).

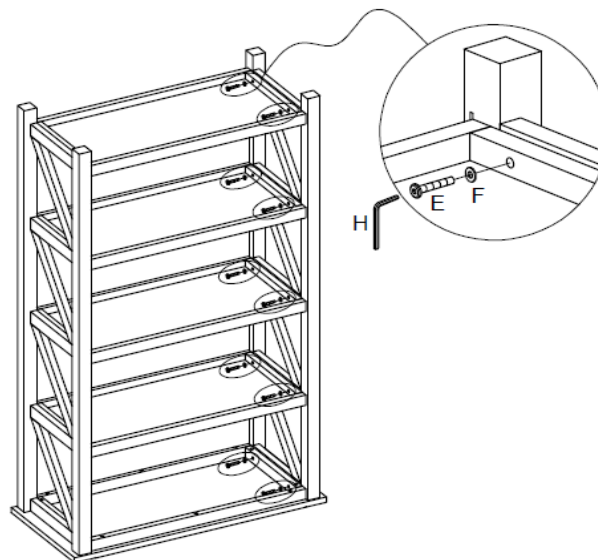

### STEP 6

A. ROTATE ASSEMBLED UNIT UPRIGHT.

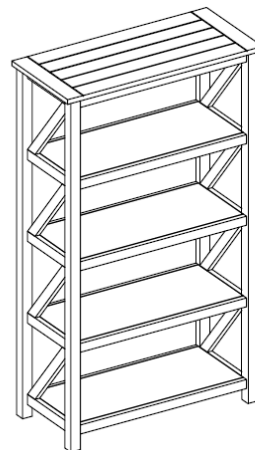

\*\* WE RECOMMEND THAT YOU SAVE THE ALLEN WRENCH AND PERIODICALLY TIGHTEN ALL BOLTS.

#### **WEIGHT LIMIT:**

TOP: 100 LBS, SHELVES: 75 LBS

#### **CARE AND CLEANING**

WIPE CLEAN WITH A SOFT, DRY CLOTH AS NEEDED.

DO NOT SIT, STAND, OR CLIMB ON THE BOOKCASE.





INTENDED FOR INDOOR USE ONLY.

FOR MISSING OR INCORRECT PARTS/HARDWARE, CONTACT THE MANUFACTURER'S CUSTOMER SERVICE DIRECTLY AT 1-847-608-5202 OR CUSTOMERSERVICE@HOMECIAO.COM

**SAVE THESE INSTRUCTIONS**  
**ANTI-TIP HARDWARE MOUNTING INSTRUCTIONS FOR DRYWALL**

PHILIPS HEAD SCREW DRIVER, DRILL, 7/32" DRILL BIT NEEDED FOR ASSEMBLY; NOT INCLUDED.  
 FOR SAFETY REASONS, WE RECOMMEND THAT YOU INSTALL THE INCLUDED ANTI-TIP HARDWARE TO HELP PREVENT THE BOOKCASE FROM UNEXPECTEDLY TIPPING OR SHIFTING.

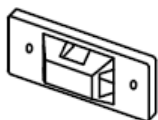
THE INCLUDED MATERIALS ARE DESIGNED TO MOUNT THE ANTI-TIP HARDWARE TO DRYWALL.  
 PLEASE CONSULT A REPRESENTATIVE AT A HARDWARE/HOME IMPROVEMENT STORE TO DISCUSS ADDITIONAL MOUNTING OPTIONS FOR OTHER TYPES OF WALLS.

PART LIST	FIGURE	QUANTITY	DESCRIPTION
I	 1/8 x 1-1/2"	2 PCS	LONG SCREW
J	 1/8 x 45/64"	2 PCS	SHORT SCREW
K		2 PCS	MOUNTING BRACKET
L		2 PCS	PLASTIC ANCHOR
M		1 PC	ZIP TIE

**STEP 1**

A. DETERMINE WHERE THE BOOKCASE IS PLACED, THEN MARK THE POSITION OF MOUNTING BRACKET ON THE WALL.

B. DRILL HOLES IN THE WALL. PRESS THE PLASTIC ANCHOR (L) INTO THE HOLES.

C. POSITION ONE END OF MOUNTING BRACKET (K) OVER THE PLASTIC ANCHOR (L) AND USE LONG SCREWS (I) TO ATTACH THE MOUNTING BRACKET (K) TO THE WALL. TIGHTEN LONG SCREWS (I) BY USING PHILLIPS HEAD SCREWDRIVER (NOT INCLUDED).

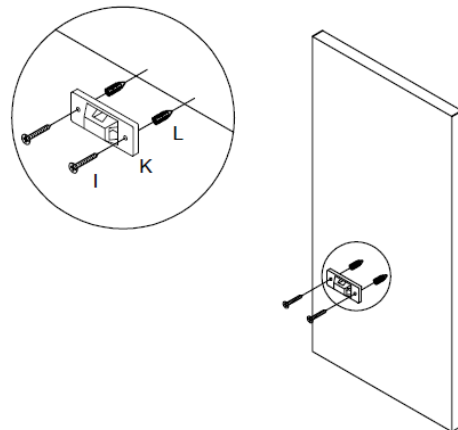

**SAVE THESE INSTRUCTIONS**  
**ANTI-TIP HARDWARE MOUNTING INSTRUCTIONS FOR DRYWALL**

**STEP 2**

A. USE SHORT SCREWS (J) TO ATTACH THE OTHER END OF MOUNTING BRACKET (K) TO THE CENTER OF SHELF FRAME OF THE FIRST TIER OF THE BOOKCASE.

B. TIGHTEN SHORT SCREWS (J) BY USING PHILLIPS HEAD SCREWDRIVER (NOT INCLUDED).

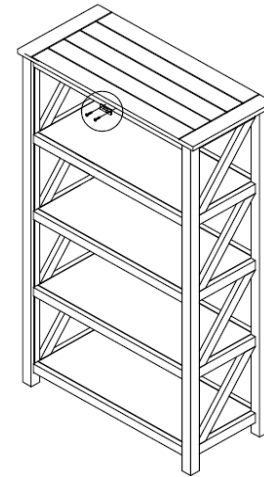
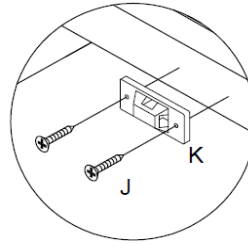

**STEP 3**

A. PLACE THE BOOKCASE SO THAT THE MOUNTING BRACKET (K) ON THE BACK OF BOOKCASE IS IN LINE WITH MOUNTING BRACKET (K) ON THE WALL.

B. FEED THE ZIP TIE (M) THROUGH EACH MOUNTING BRACKET (K) AND SECURE IT.

C. CHECK TO MAKE SURE THE ZIP TIE (M) IS SECURELY TIGHTENED AND LOCKED TO MOUNTING BRACKETS (K).

