

SAVE THESE INSTRUCTIONS
SONOMA CAMERON RECLINER TABLE CARE INSTRUCTIONS

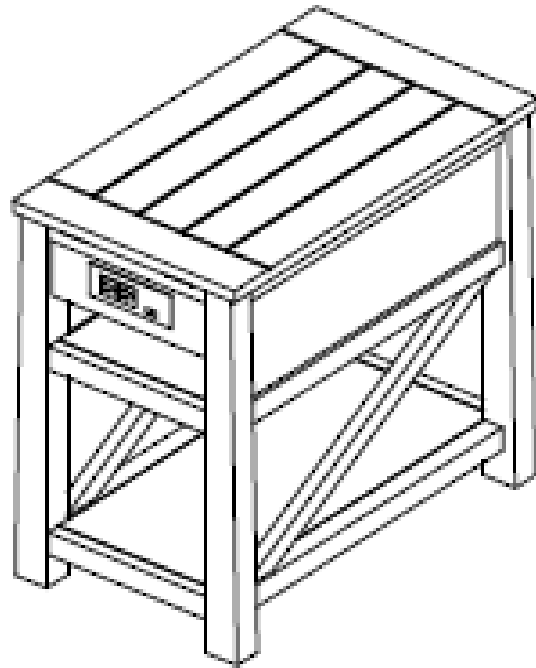
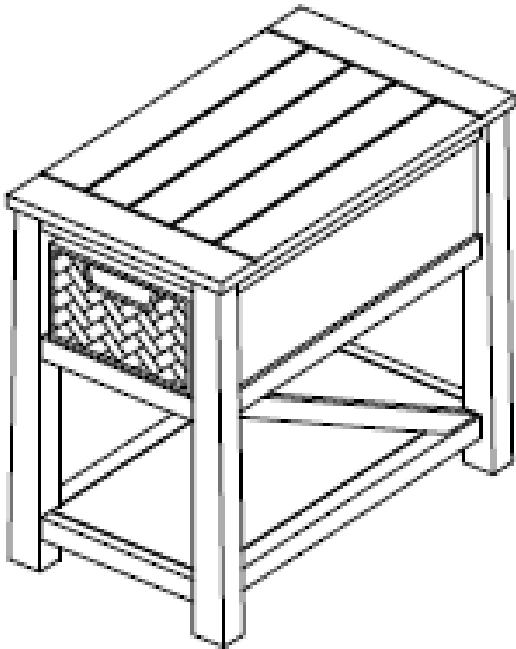

CAUTION:

- KEEP OUT OF REACH OF CHILDREN.
- NEVER TOUCH ELECTRICAL PLUGS WITH WET HANDS.
- SWITCH OFF THE POWER SUPPLY OR UNPLUG FROM THE ELECTRIC OUTLET WHEN NOT IN USE AND BEFORE CLEANING.
- POWER DISTRIBUTIONS UNITS: 125VAC 60Hz 12A MAX. 1500W.
- DO NOT USE POLISHES OR CLEANERS. WIPE CLEAN WITH SOFT, DRY CLOTH AS NEEDED.
- BASKET: DO NOT BRING IN CONTACT WITH WATER OR LIQUIDS.
- DO NOT SIT, STAND OR CLIMB ON TABLE.
- WEIGHT RESTRICTION: TOP: 40 LBS, SHELVES: 20 LBS EACH, BASKET: 15 LBS.
- INTENDED FOR INDOOR USE ONLY.

FOR MISSING OR INCORRECT PARTS/HARDWARE, CONTACT THE MANUFACTURER'S CUSTOMER SERVICE DIRECTLY AT 1-847-608-5202 OR CUSTOMERSERVICE@HOMECIAO.COM