

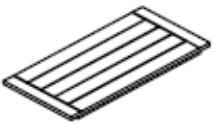

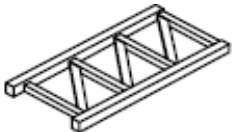

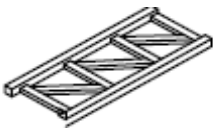



SAVE THESE INSTRUCTIONS

SONOMA CAMERON 6 DRAWER STORAGE TOWER ASSEMBLY INSTRUCTIONS

ASSEMBLE ON A FLAT, PROTECTED SURFACE

PART LIST	FIGURE	QUANTITY	DESCRIPTION
A		1 PC	TOP
B		1 PC	RIGHT SIDE FRAME
C		1 PC	LEFT SIDE FRAME
D		3 PCS	SHELF
E		6 PCS	BASKET
F		6 PCS	BASKET BOTTOM
G		16 PCS + 1 PC	BOLT
H		16 PCS + 1 PC	FLAT WASHER
I		8 PCS + 1 PC	WOOD DOWEL
J		1 PC	ALLEN WRENCH

FOR MISSING OR INCORRECT PARTS/HARDWARE, CONTACT THE MANUFACTURER'S CUSTOMER SERVICE DIRECTLY AT
 1-847-608-5202 OR CUSTOMERSERVICE@HOMECIAO.COM
 REFER TO LAST PAGE FOR ADDITIONAL CUSTOMER SERVICE DETAILS.

ASSEMBLY INSTRUCTIONS (CONTINUED)

STEP 1

A. PLACE TOP (A) UPSIDE DOWN ON A FLAT, PROTECTED SURFACE.

B. INSERT WOOD DOWELS (I) INTO DOWEL HOLES IN TOP (A) AS SHOWN.

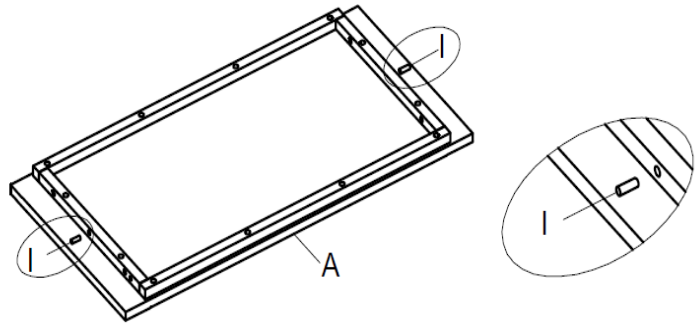

STEP 2

A. INSERT WOOD DOWELS (I) INTO THE DOWEL HOLES IN SHELVES (D) AS SHOWN.

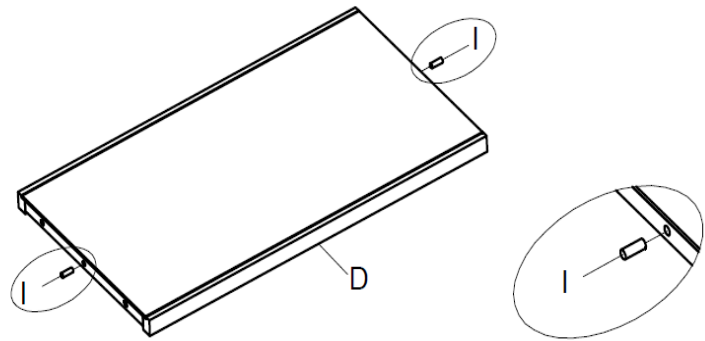

STEP 3

A. ATTACH RIGHT SIDE FRAME (B) TO TOP (A) WITH BOLTS (G) AND FLAT WASHERS (H) USING ALLEN WRENCH (J). DO NOT TIGHTEN COMPLETELY.

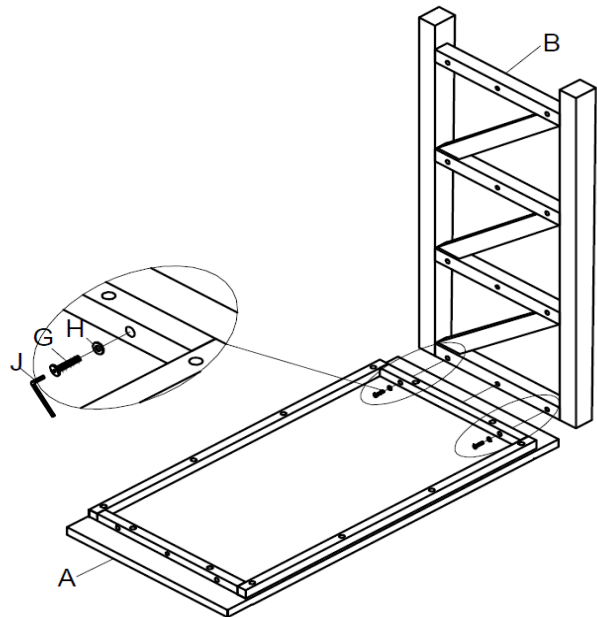

ASSEMBLY INSTRUCTIONS (CONTINUED)

STEP 4

A. ROTATE THE ASSEMBLED UNIT FROM STEP 3 ON ITS SIDE ON A FLAT, PROTECTED SURFACE.

B. ATTACH SHELVES (D) TO THE ASSEMBLED UNIT WITH BOLTS (G) AND FLAT WASHERS (H) USING ALLEN WRENCH (J). DO NOT TIGHTEN COMPLETELY.

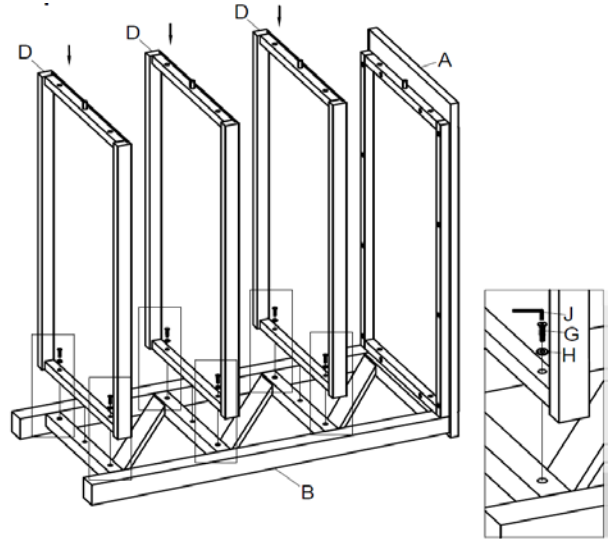

STEP 5

A. ALIGN LEFT SIDE FRAME (C) TO TOP (A) AND SHELVES (D) AS SHOWN.

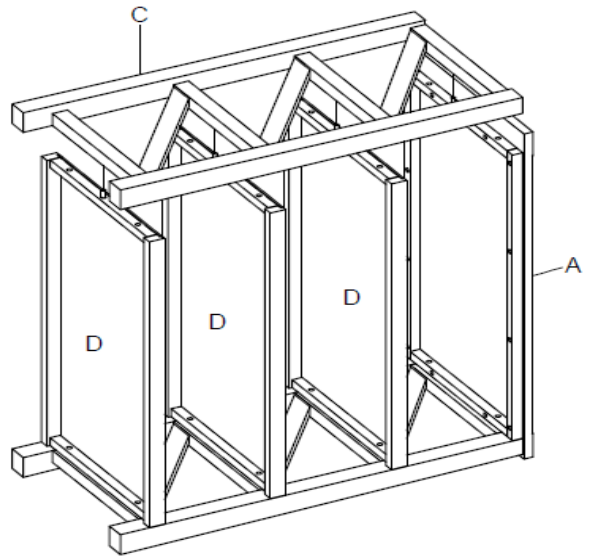

STEP 6

A. CAREFULLY ROTATE THE ASSEMBLED UNIT UPSIDE DOWN ON A FLAT, PROTECTED SURFACE.

B. ATTACH TOP (A) AND SHELVES (D) TO LEFT SIDE FRAME (C) WITH BOLTS (G) AND FLAT WASHERS (H) USING ALLEN WRENCH (J).

C. TIGHTEN COMPLETELY ALL BOLTS (G).

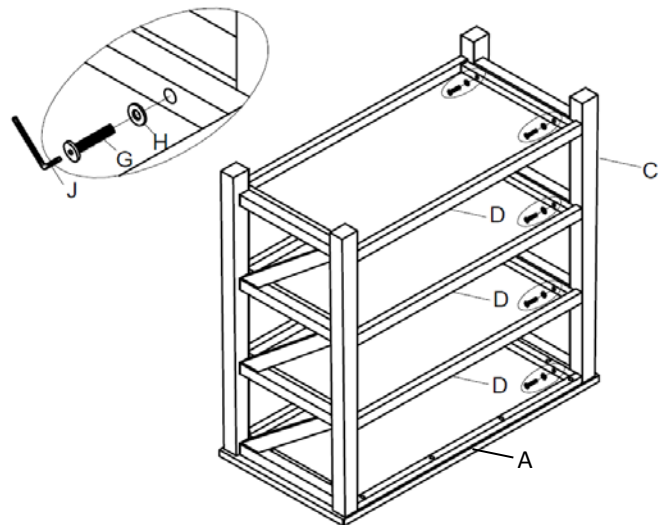

ASSEMBLY INSTRUCTIONS (CONTINUED)

STEP 7

- A. INSERT BASKET BOTTOMS (F) INTO BASKETS (E).
- B. REPEAT FOR REMAINING BASKETS.

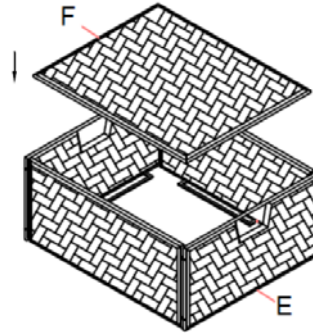

STEP 8

- A. ROTATE THE ASSEMBLED UNIT TO UPRIGHT POSITION.
- B. PLACE THE ASSEMBLED BASKETS ONTO THE SHELVES AS SHOWN.
- C. ASSEMBLY IS COMPLETE.

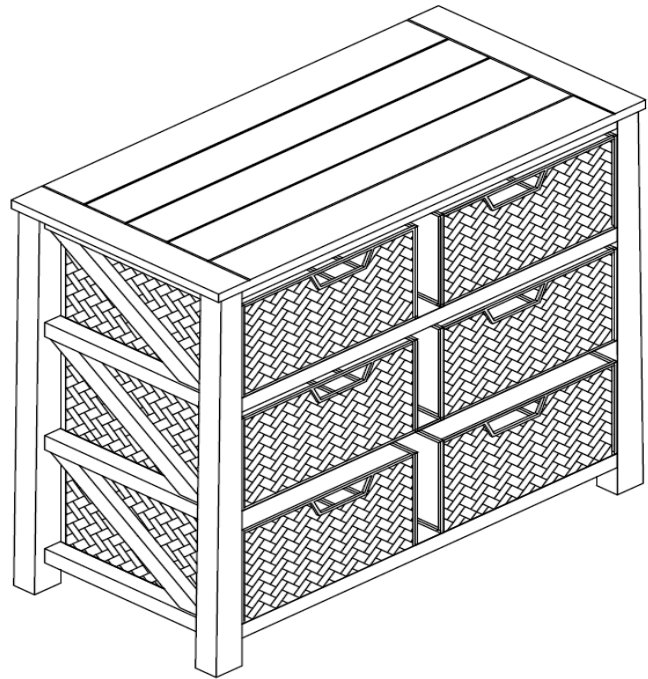

**** WE RECOMMEND THAT YOU SAVE THE ALLEN WRENCH AND PERIODICALLY TIGHTEN ALL BOLTS.**

WEIGHT LIMIT:

TOP: 50 LBS, SHELVES: 40 LBS EACH, BASKETS: 20 LBS EACH.

CARE AND CLEANING

WIPE CLEAN WITH A SOFT, DRY CLOTH AS NEEDED.

BASKETS: DO NOT BRING IN CONTACT WITH WATER OR LIQUIDS.

DO NOT SIT, STAND, OR CLIMB ON THE TOWER.





INTENDED FOR INDOOR USE ONLY.

FOR MISSING OR INCORRECT PARTS/HARDWARE, CONTACT THE MANUFACTURER'S CUSTOMER SERVICE DIRECTLY AT 1-847-608-5202 OR CUSTOMERSERVICE@HOMECIAO.COM

SAVE THESE INSTRUCTIONS
ANTI-TIP HARDWARE MOUNTING INSTRUCTIONS FOR DRYWALL

PHILIPS HEAD SCREW DRIVER, DRILL, 7/32" DRILL BIT NEEDED FOR ASSEMBLY; NOT INCLUDED.
 FOR SAFETY REASONS, WE RECOMMEND THAT YOU INSTALL THE INCLUDED ANTI-TIP HARDWARE TO HELP PREVENT THE STORAGE TOWER FROM UNEXPECTEDLY TIPPING OR SHIFTING.

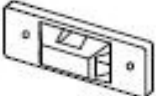
THE INCLUDED MATERIALS ARE DESIGNED TO MOUNT THE ANTI-TIP HARDWARE TO DRYWALL.
 PLEASE CONSULT A REPRESENTATIVE AT A HARDWARE/HOME IMPROVEMENT STORE TO DISCUSS ADDITIONAL MOUNTING OPTIONS FOR OTHER TYPES OF WALLS.

PART LIST	FIGURE	QUANTITY	DESCRIPTION
K	 1/8 x 1-1/2"	2 PCS	LONG SCREW
L	 1/8 x 45/64"	2 PCS	SHORT SCREW
M		2 PCS	MOUNTING BRACKET
N		2 PCS	PLASTIC ANCHOR
O		1 PC	ZIP TIE

STEP 1

A. DETERMINE WHERE THE STORAGE TOWER WILL BE PLACED, THEN MARK THE POSITION OF MOUNTING BRACKET ON THE WALL.

B. DRILL HOLES IN THE WALL. PRESS THE PLASTIC ANCHOR (N) INTO THE HOLES.

C. POSITION ONE END OF MOUNTING BRACKET (M) OVER THE PLASTIC ANCHOR (N) AND USE LONG SCREWS (K) TO ATTACH THE MOUNTING BRACKET (M) TO THE WALL. TIGHTEN LONG SCREWS (K) BY USING PHILLIPS HEAD SCREWDRIVER (NOT INCLUDED).

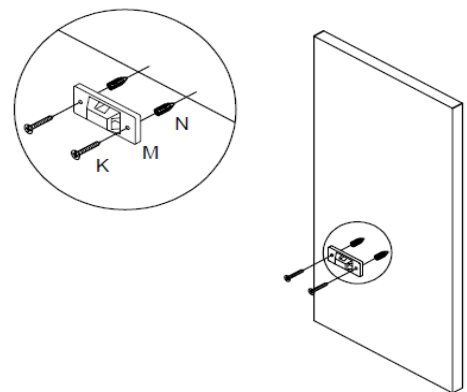

SAVE THESE INSTRUCTIONS
ANTI-TIP HARDWARE MOUNTING INSTRUCTIONS FOR DRYWALL

STEP 2

A. USE SHORT SCREWS (L) TO ATTACH THE OTHER END OF MOUNTING BRACKET (M) TO THE CENTER OF SHELF FRAME OF THE FIRST TIER OF THE STORAGE TOWER.

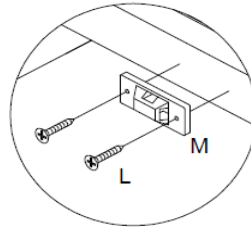

B. TIGHTEN SHORT SCREWS (L) BY USING PHILLIPS HEAD SCREWDRIVER (NOT INCLUDED).

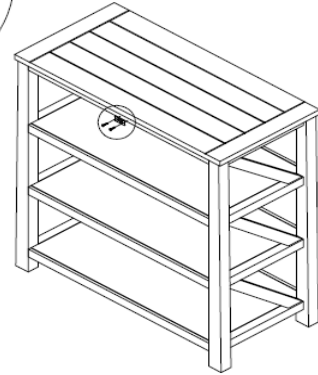

STEP 3

A. PLACE THE STORAGE UNIT SO THAT THE MOUNTING BRACKET (M) ON THE BACK OF STORAGE UNIT IS IN LINE WITH MOUNTING BRACKET (M) ON THE WALL.

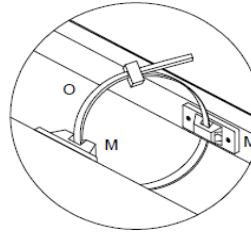

B. FEED THE ZIP TIE (O) THROUGH EACH MOUNTING BRACKET (M) AND SECURE IT.

C. CHECK TO MAKE SURE THE ZIP TIE (O) IS SECURELY TIGHTENED AND LOCKED TO MOUNTING BRACKETS (M).

