









# SAVE THESE INSTRUCTIONS

## SONOMA BRAMPTON CORNER CHAIR ASSEMBLY INSTRUCTIONS

STYLE #: 71SRRWK01

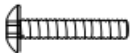
ASSEMBLE ON A FLAT, PROTECTED SURFACE.

PART LIST	FIGURE	QUANTITY	DESCRIPTION
A		1 PC	LEFT CHAIR BACK
B		1 PC	RIGHT CHAIR BACK
C		1 PC	CHAIR SEAT
D		1 PC	SEAT CUSHION
E		1 PC	LEFT BACK CUSHION
F		1 PC	RIGHT BACK CUSHION
G		8 PCS + 1 PC	BOLT (M6*40MM)
H		8 PCS + 1 PC	FLAT WASHER
I		1 PC	ALLEN WRENCH

## ASSEMBLY INSTRUCTIONS (CONTINUED)

STYLE #: 71SRRWK01

### STEP 1

A. PLACE CHAIR SEAT (C) ON ITS SIDE ON A FLAT, PROTECTED SURFACE.

B. CONNECT LEFT CHAIR BACK (A) TO CHAIR SEAT (C) WITH FLAT WASHER (H) AND BOLT (G) USING ALLEN WRENCH (I). DO NOT TIGHTEN COMPLETELY.

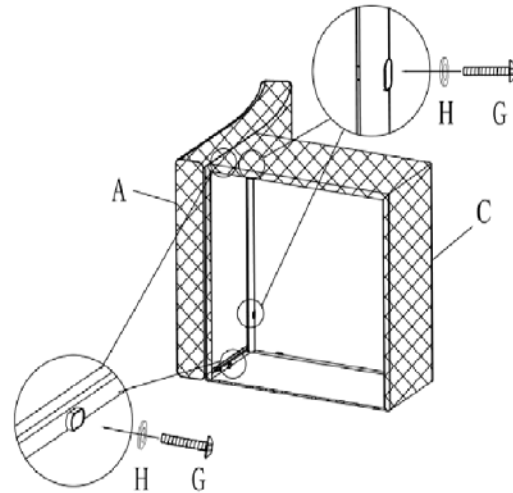

### STEP 2

A. ROTATE CHAIR WITH LEFT CHAIR BACK (A) UP.

B. CONNECT RIGHT CHAIR BACK (B) TO CHAIR SEAT (C) WITH FLAT WASHER (H) AND BOLT (G) USING ALLEN WRENCH (I). DO NOT TIGHTEN COMPLETELY.

C. TIGHTEN COMPLETELY ALL BOLTS (G) FROM STEPS 1 & 2.

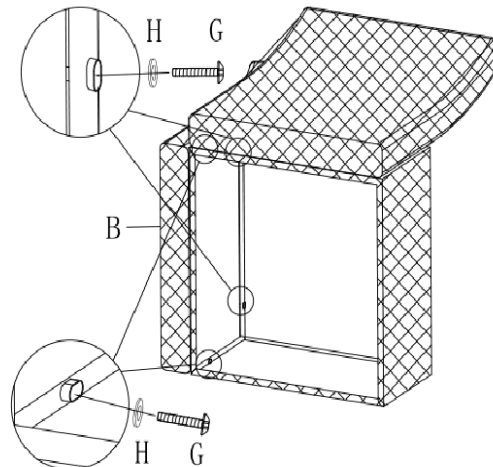

### STEP 3

A. ROTATE CHAIR TO UPRIGHT POSITION.

B. PLACE THE SEAT CUSHION (D) ON CHAIR SEAT (C).

C. PLACE RIGHT BACK CUSHION (F) AND LEFT BACK CUSHION (E) INTO POSITION.

D. ASSEMBLY IS COMPLETE.

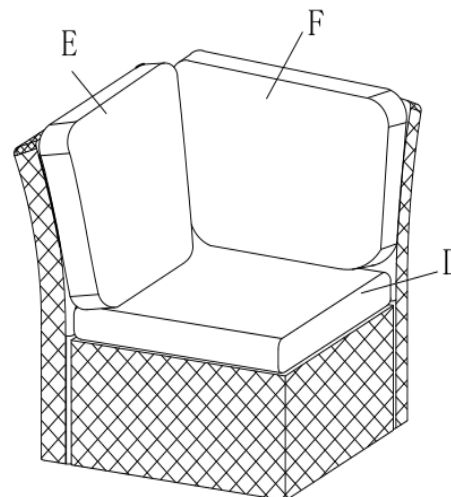

## **ASSEMBLY INSTRUCTIONS (CONTINUED)**

**STYLE #: 71SRRWK01**

\*\* WE RECOMMEND THAT YOU SAVE THE ALLEN WRENCH AND PERIODICALLY TIGHTEN ALL BOLTS.

### **WEIGHT LIMIT**

250 LBS

### **CARE AND CLEANING**

FRAME: WIPE CLEAN WITH A MILD SOAP AND WATER SOLUTION, RINSE WITH CLEAN WATER, AND DRY THOROUGHLY.

CUSHION: SPOT CLEAN WITH A SOFT CLOTH.

DO NOT STAND OR CLIMB ON CHAIR.

IN ORDER TO PROLONG THE LIFE OF YOUR CHAIR, PLEASE STORE IN DRY SHELTERED PLACE WHEN NOT IN USE OR DURING INCLEMENT WEATHER.

### **WARRANTY**

1 YEAR LIMITED WARRANTY FOR FRAME.

CUSTOMER SERVICE: PLEASE NOTE - DO NOT RETURN THIS ITEM TO THE RETAILER.

CUSTOMER SERVICE HOT LINE: 1-866-905-4107

WEBSITE: [WWW.YOTRIOINT.COM](http://WWW.YOTRIOINT.COM)

TO ASSIST YOU BETTER, PLEASE GATHER THE FOLLOWING INFORMATION BEFORE CALLING CUSTOMER SERVICE:

PRODUCT NAME AND STYLE NUMBER, DESCRIPTION AND OR IMAGES OF THE ISSUE, ORIGINAL STORE PURCHASE RECEIPT.