

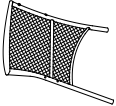

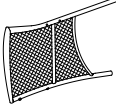



## SAVE THESE INSTRUCTIONS

### SONOMA BISCAIY 5PC CHAT SET CHAIR ASSEMBLY INSTRUCTIONS

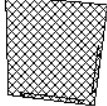
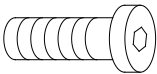
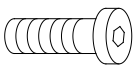
STYLE #: 61SRR4503BIS

ASSEMBLE ON A FLAT, PROTECTED SURFACE

PART LIST	FIGURE	QUANTITY	DESCRIPTION
A		1 PC	LEFT SIDE
B		1 PC	RIGHT SIDE
C		1 PC	SEAT
D		1 PC	BACK
E		6 PCS + 1 PC	LONG BOLT (M6*40MM)
F		4 PCS + 1 PC	SHORT BOLT (M6*20MM)
G		10 PCS + 1 PC	FLAT WASHER
H		1 PC	ALLEN WRENCH
I		1 PC	CUSHION

**ASSEMBLY INSTRUCTIONS (CONTINUED)**

**STYLE #: 61SRR4503BIS**

**STEP 1**

A. ATTACH BACK (D) TO LEFT SIDE (A) AND RIGHT SIDE (B) WITH LONG BOLTS (E) AND FLAT WASHERS (G) USING ALLEN WRENCH (H). DO NOT TIGHTEN COMPLETELY.

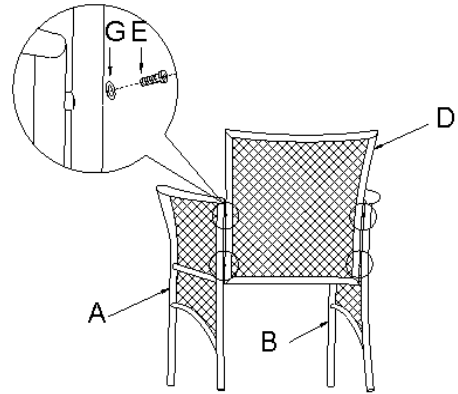

**STEP 2**

A. ROTATE PREASSEMBLED UNIT UPSIDE DOWN.

B. CONNECT SEAT (C) TO BACK (D) WITH LONG BOLTS (E) AND FLAT WASHERS (G). DO NOT TIGHTEN COMPLETELY.

C. CONNECT SEAT (C) TO LEFT SIDE (A) AND RIGHT SIDE (B) WITH SHORT BOLTS (F) AND FLAT WASHERS (G) USING ALLEN WRENCH (H). DO NOT TIGHTEN COMPLETELY.

D. TIGHTEN COMPLETELY ALL BOLTS (E & F) USING ALLEN WRENCH (H).

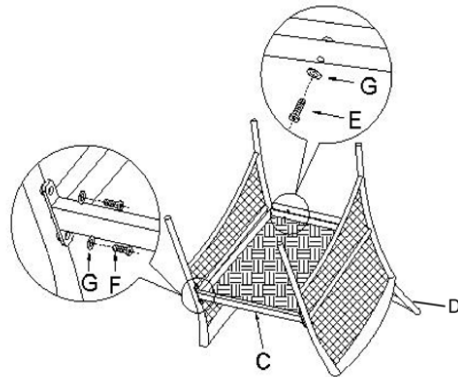

**STEP 3**

A. ROTATE CHAIR TO THE UPRIGHT POSITION.

B. PLACE CUSHION (I) ON SEAT (C).

C. ASSEMBLY IS COMPLETE.

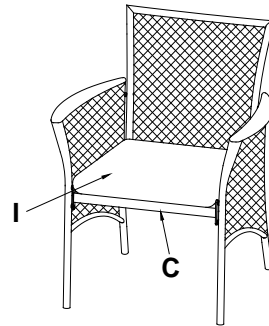



## SAVE THESE INSTRUCTIONS

### SONOMA BISCAIY 5PC CHAT SET OTTOMAN ASSEMBLY INSTRUCTIONS

STYLE #: 61SRR4503BIS

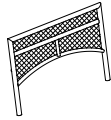
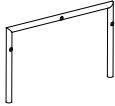
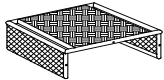
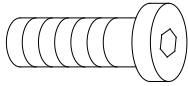
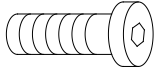
ASSEMBLE ON A FLAT, PROTECTED SURFACE

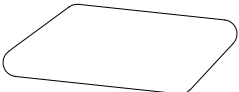
PART LIST	FIGURE	QUANTITY	DESCRIPTION
A		1 PC	FRONT LEG
B		1 PC	BACK LEG
C		1 PC	TOP
D		2 PCS + 1 PC	LONG BOLT (M6*35MM)
E		4 PCS + 1 PC	SHORT BOLT (M6*25MM)
F		6 PCS + 1 PC	FLAT WASHER
G		1 PC	ALLEN WRENCH
H		1 PC	CUSHION

## ASSEMBLY INSTRUCTIONS (CONTINUED)

STYLE #: 61SRR4503BIS

### STEP 1

- A. PLACE TOP (C) UPSIDE DOWN ON A FLAT, PROTECTED SURFACE.
- B. ATTACH TOP (C) TO FRONT LEG (A) AND BACK LEG (B) WITH SHORT BOLTS (E) AND FLAT WASHERS (F) USING ALLEN WRENCH (G). DO NOT TIGHTEN COMPLETELY.

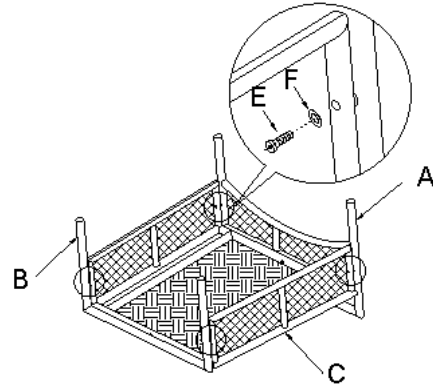

### STEP 2

- A. CONNECT CENTER OF TOP (C) TO CENTER OF FRONT LEG (A) AND BACK LEG (B) WITH LONG BOLTS (D) AND FLAT WASHERS (F) USING ALLEN WRENCH (G). DO NOT TIGHTEN COMPLETELY.
- B. TIGHTEN COMPLETELY ALL BOLTS (D & E) WITH ALLEN WRENCH (G).

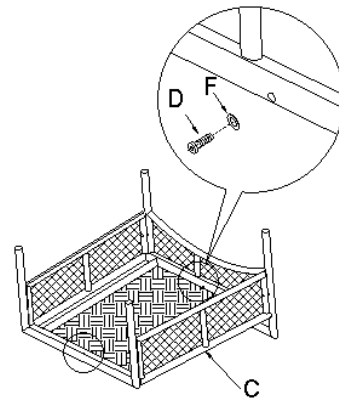

### STEP 3

- A. ROTATE OTTOMAN TO THE UPRIGHT POSITION.
- B. PLACE CUSHION (H) ON OTTOMAN.
- C. ASSEMBLY IS COMPLETE.

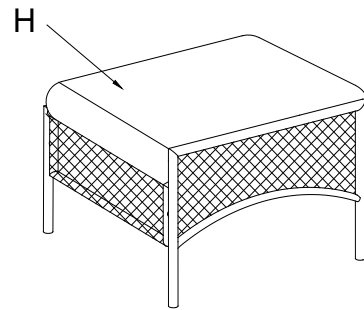





## SAVE THESE INSTRUCTIONS

### SONOMA BISCAY 5PC CHAT SET TABLE ASSEMBLY INSTRUCTIONS

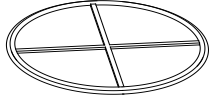
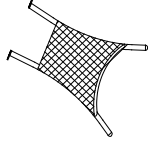
STYLE #: 61SRR4503BIS

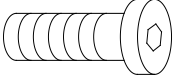
ASSEMBLE ON A FLAT, PROTECTED SURFACE

PART LIST	FIGURE	QUANTITY	DESCRIPTION
A		1 PC	TOP FRAME
B		2 PCS	LEG CAP
C		2 PCS	LEG CONNECTOR
D		1 PC	GLASS TOP
E		12 PCS + 1 PC	BOLT (M6*15MM)
F		12 PCS + 1 PC	FLAT WASHER
G		1 PC	ALLEN WRENCH

## ASSEMBLY INSTRUCTIONS (CONTINUED)

STYLE #: 61SRR4503BIS

### STEP 1

A. PLACE TOP FRAME (A) UPSIDE DOWN ON A FLAT, PROTECTED SURFACE.

B. ATTACH LEGS (B) TO TOP FRAME (A) WITH BOLTS (E) AND FLAT WASHERS (F) USING ALLEN WRENCH (G). DO NOT TIGHTEN COMPLETELY.

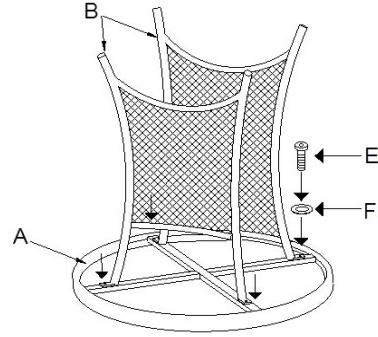

### STEP 2

A. ATTACH LEG CONNECTERS (C) TO LEGS (B) WITH BOLTS (E) AND FLAT WASHERS (F) USING ALLEN WRENCH (G). DO NOT TIGHTEN COMPLETELY.

B. TIGHTEN COMPLETELY ALL BOLTS (E) WITH ALLEN WRENCH (G).

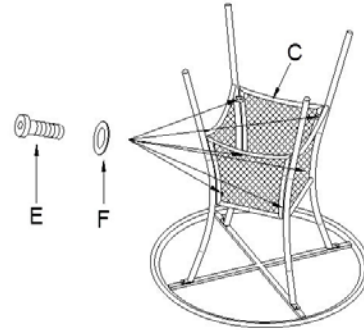

### STEP 3

A. ROTATE ASSEMBLED UNIT TO THE UPRIGHT POSITION.

B. PLACE GLASS TOP (D) ONTO TOP FRAME (A).

C. ADJUST LEVERLS ON BOTTOM SO THE TABLE IS STABLE ON THE FLOOR.

D. ASSEMBLY IS COMPLETE.

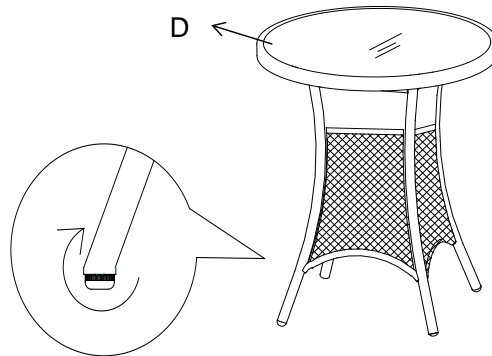

\*\* WE RECOMMEND THAT YOU SAVE THE ALLEN WRENCH (G) AND PERIODICALLY TIGHTEN ALL BOLTS.

#### WEIGHT LIMIT

CHAIR: 300 LBS; OTTOMAN: 150 LBS; SIDE TABLE: 50 LBS

#### CARE AND CLEANING

FRAME: WIPE CLEAN WITH A SOFT, DAMP CLOTH AS NEEDED.

CUSHION: SPOT CLEAN WITH A DAMP, CLEAN CLOTH AS NEEDED.

DO NOT STAND OR CLIMB ON THE CHAIR OR OTTOMAN.

DO NOT SIT, STAND, OR CLIMB ON THE TABLE.

#### WARRANTY

1 YEAR LIMITED WARRANTY. COMMERCIAL USE, ACTS OF NATURE, FIRE, FREEZING, ABUSIVE USE, DISCOLORATION OR FADING OF THE FINISH OR FABRICS AS RESULT OF CHEMICALS OR SPILLS IS NOT COVERED. PROOF OF PURCHASE (DATED RECEIPT) IS REQUIRED FOR WARRANTY CLAIMS. WE RESERVE THE RIGHT TO MAKE SUBSTITUTIONS WITH SIMILAR MERCHANDISE.